



European Organisation for Technical Approvals
Europäische Organisation für Technische Zulassungen
Organisation Européenne pour l'Agrément Technique

Established pursuant to Annex II of the Council Directive 89/106 of 21 December 1988 on the approximation of laws, regulations and administrative provisions of Member States relating to construction products (Construction Products Directive)

ETAG 27

GUIDELINE FOR
EUROPEAN TECHNICAL APPROVAL
of
FALLING ROCK PROTECTION KITS

Edition 2008 - 02 - 01

Established and published in accordance with Article 11 of the Construction Products Directive as a basis for the preparation and issue of European technical approvals in accordance with Article 9.1 of the Construction Products Directive

European technical approvals are issued by approval bodies authorised and notified in accordance with Article 10 of the Construction Products Directive. These bodies are organized in EOTA.

The European technical approval, according to the Construction Products Directive, is a favourable technical assessment of the fitness for use of a construction product and the technical specification of the assessed product, serving as basis for the CE marking of this product when and where a harmonised standard according to the Directive is not or not yet available.

Due to technical innovation and the progress of the state of the art, guidelines for technical approval might not reflect the latest developments and experiences gained in approval procedures. The reader of this Guideline is therefore advised to check with an EOTA member whether there are further provisions which have to be taken into account in the use of the Guideline.

[Copy right: EOTA]

Table of contents

1	Scope of the ETAG.....	4
1.1.	Definition of the construction product	4
1.2.	Intended use of the construction product.....	6
1.3.	Assumed working life of the construction product	7
1.4.	Terminology	7
1.4.1.	Common terms relating to the Construction Products Directive	7
1.4.2.	Specific terms used in this ETAG.....	7
1.5.	Procedure in the case of a significant deviation from the ETAG.....	11
2	assessment of fitness for use.....	11
2.1.	Meaning of "fitness for use"	11
2.2.	Elements of the assessment of fitness for use	11
2.3.	Relationship of requirements to the characteristics of the assembled system and its components and methods of verification and assessment	12
2.4.	Characteristics of the assembled system which are relevant for the fitness for use.....	13
2.4.1.	Energy absorption of the assembled system: Service Energy Level (SEL)	13
2.4.2.	Energy absorption of the assembled system: Maximum Energy Level (MEL)	13
2.4.3.	Classification of the assembled system.....	14
2.4.4.	Deformation characteristics of the assembled system: Residual height	14
2.4.5.	Deformation characteristics of the assembled system: maximum elongation	14
2.4.6.	Action on the foundations of the assembled system	15
2.4.7.	Durability of the assembled system.....	15
2.4.8.	Dangerous substances.....	15
3	Evaluation and attestation of conformity and CE marking.....	16
3.1.	System of attestation of conformity.....	16
3.2.	Tasks and responsibilities of the manufacturer and notified bodies	16
3.2.1.	Tasks of the manufacturer	16
3.2.2.	Tasks of notified bodies	21
3.3.	CE marking and accompanying information	22
3.3.1.	Example 1	23
3.3.2.	Example 2.....	23
3.3.3.	Location of CE Marking.....	23
4	Assumptions under which the fitness for the intended use is assessed	24
4.1.	Manufacture of the kit	24
4.2.	Packaging, transport, storage of the kit	24
4.3.	Assembly and installation of the kit in the works	24

4.4. Use, maintenance, repair	25
5 Identification of the kit	25
5.1. Means of identification.....	25
5.2. Components of the assembled system and their characteristics which are relevant for identification checking	26
5.2.1. Ropes	26
5.2.2. Energy dissipating devices	27
5.2.3. Net elements	27
5.2.4. Post	28
6 Format of Etas issued on the basis of the ETAG.....	29
7 Reference documents	29
Annex A – Impact test method.....	33
Annex B – Test report format.....	39
Annex C – Identification test.....	44
Addendum Format of ETAs issued on the basis of the ETAG.....	48

1 SCOPE OF THE ETAG

1.1. Definition of the construction product

A "kit" is a special form of a "construction product" in the sense of the CPD. It consists of several "components" which are

- placed on the market together with one common CE marking,
- assembled on site, and thus
- become an "assembled system" when installed in the construction works.

A kit component may itself, as a construction product in the sense of the CPD, bear the CE marking on its own right on the basis of a product EN or ETA. Nevertheless, it may need to be assessed again as component of the kit.

This ETAG is applicable to falling rock protection kits, which should be made up of one or more identical functional module placed in sequence, which would permit adjusting the length of the barrier to the sliding site and to the work to be protected. Each functional module should:

- foresee the easy substitution of each component and permit the substitution of any damaged elements;
- foresee the easy set up of the structure on the ground and an easy construction on the site.

The minimum content of a kit covered by this guideline consists of a 3 functional module (3FM). 3FM means 3 fields of net fences and 4 posts. The spacing of the posts is not fixed, and shall be chosen by the producer.

A falling rock protection kit is made up of:

- a) an *interception structure*, which has the function of bearing the direct impact of the mass, deforming elastically and/or plastically, and transmitting the stresses to the connection components, the support structure and the foundations;
- b) a *support structure*, which has the function of maintaining the interception structure unbent, which is by nature not rigid. It can be directly connected to the interception structure or through a connection structure.
- c) *connection components*, which have the function of transmitting the stresses to the foundation. In order to allow the deformation, devices can be installed onto the structure, which permit a controlled lengthening.

The foundation is not considered part of the kit. The design of the foundation is in the responsibility of the designer, taking account of national provisions.

The following table summarizes the components, which form the various main parts:

Main parts	Components	Function
Interception structure	Principal net: made up of metallic cables, wires and / or bars of different types and materials (for example cable nets joined with clamps, submarine nets and ring nets. in the last two cases the rings forming the net are connected each other). Additional layers: usually with a finer meshwork than the principal net made up of cables and or wires or other materials.	Bearing the direct impact of the mass, deforming elastically and/or plastically, and transmitting the stresses to the connection components, the support structure and the foundations.

Main parts	Components	Function
Support structure	Posts made of different materials geometries and length (for example, pipes, structural metallic elements) and which may be provided at the bottom with a hinge.	Maintains the interception structure erected. It can be connected to the interception structure directly or through the connection components.

Main parts	Components	Function
Connection components	Connecting ropes, steel cables, wires and / or bars of different types and materials, junctions, clamps, energy dissipating devices (elements which are able to dissipate energy and/or allow a controlled displacement when stressed).	Transmit the stresses to the foundation structure during impact and/or maintains the interception structure in position.

Main parts	Components	Function
Foundation	Not part of the ETAG.	Transmits the forces derived from the block impact to the ground.

The followings schemes (Figures n°1 & 2) give an example of a kit and explain in general terms the different components of the kit

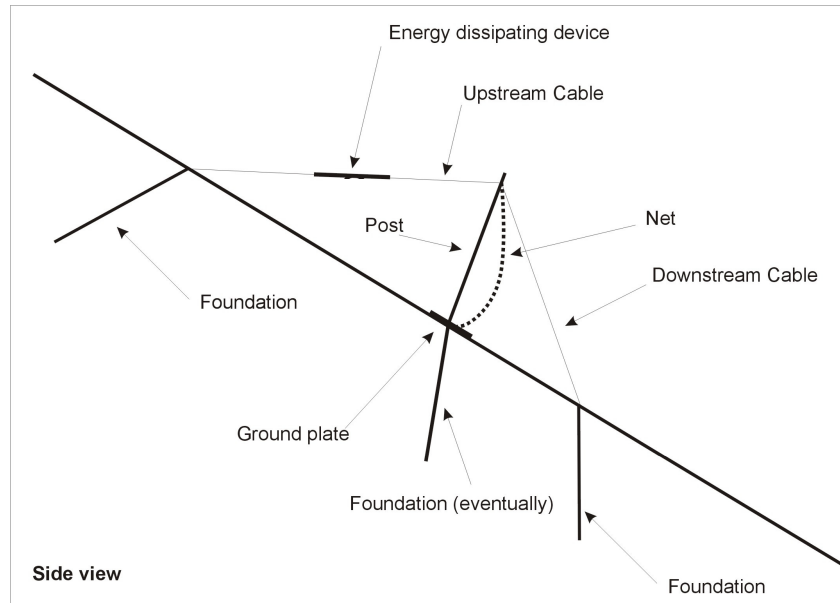

Fig. 1. Lateral view of a falling rock protection kit

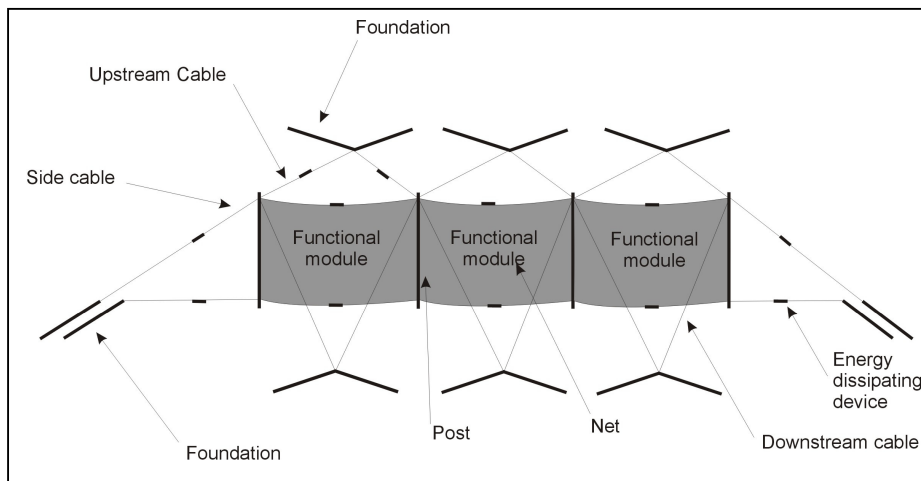

Fig. 2. Back view of a falling rock protection kit

1.2. Intended use of the construction product

This ETAG concerns the falling rock protection kits used to stop moving rock blocks on a slope with a minimum service energy level.

The products are designed, manufactured and installed in accordance with the ETA holder's concept and installation guide.

A range of ambient temperature [- 40°C ; + 50 °C] that covers the general situation met in the different countries shall be fulfilled for every product. The manufacturer can indicate the range of ambient temperature beyond the given range, at which he wants his kit to be assessed. The influence of the temperature at the limited value of this level, chosen by the manufacturer, shall be demonstrated by appropriate test(s)/verification (i.e. appropriate steel or aluminium alloy for low temperature; brittleness test for rubber at low temperature if relevant, etc.).

Conditions for singular components of the kit to be put on the market separately are not covered by this ETAG.

Not also covered by this guideline:

- Net fences designed to prevent triggering of avalanches
- Nets attached to the slope surface to prevent detachment of rocks and stones

The proposed test procedure is valid for kits with a MEL as defined in 2.5.1.2. larger or equal to 100 kJ. The test energy has to be declared before the test by the kit producer.

1.3. Assumed working life of the construction product

The provisions and the verification and assessment methods included or referred to in this ETAG have been written based upon the assumed working life of the falling rock protection kit for the intended use of 25 years when installed in the works, provided that the falling rock protection kit is subject to appropriate installation, use and maintenance (see 4.3 and 4.4). These provisions are based upon the current state of the art and the available knowledge and experience.

This working life is intended to be assumed without any rock impact and under normal environmental conditions. After each impact, the barrier should be checked and, eventually, subject to normal maintenance or substituted. In environmental aggressive conditions, the assumed working life shall be at least 10 years with appropriate maintenance.

"Assumed working life" means that, when an assessment following the ETAG provisions is made, and when this working life has elapsed, the real working life may be, in normal use conditions, considerably longer without major degradation affecting the Essential Requirements¹.

The indications given as to the working life of the falling rock protection kit cannot be interpreted as a guarantee given by the kit manufacturer or his representative or the approval body issuing the ETA, but are regarded only as a means for choosing the appropriate products in relation to the expected economically reasonable working life of the works (see 5.2.2 of Interpretative Documents).

1.4. Terminology

1.4.1. Common terms relating to the Construction Products Directive

For the meaning of these terms see EOTA document "Common terms used in Guidelines for European technical approval" published on the EOTA website.

1.4.2. Specific terms used in this ETAG

1.4.2.1. Falling rock protection kit

Construction product consisting of nets (interception structure acc. to cl. 1.1), posts (support structure acc. to cl. 1.1), ropes (connection structure acc. to cl. 1.1) and brakes (connection structure acc. to cl. 1.1).

1.4.2.2. Nets

Bearing element acting as a surface.

¹ The real working life of a product incorporated in a specific works depends on the environmental conditions to which that works is subject and the particular conditions of the design, execution, use and maintenance of that works may be outside this ETAG. Therefore, it cannot be excluded that in these cases the real working life of the product may also be shorter than the assumed working life.

1.4.2.3. Posts:

Part of the support structure supporting the bearing ropes and nets.

1.4.2.4. Ropes (bearing)

Bearing elements serving to transmit the forces into the posts, ground plates and upstream cables.

1.4.2.5. Upstream cables

Upslope cables serving to transmit the posthead forces to the anchorage.

1.4.2.6. Downstream cables

Downslope cables serving to hold the posts in erected position.

1.4.2.7. Side cables

Cables serving to hold the end posts in correct position.

1.4.2.8. Energy dissipating device

Device (in ropes) in order to absorb energy.

1.4.2.9. Additional layer (Secondary mesh)

Wire mesh fastened to the net on the upslope side.

1.4.2.10. Anchorages

Bearing element transmitting the rope forces and post forces into the ground.

1.4.2.11. Energy level

The Energy Level of a falling rock protection kit is defined as the kinetic energy of a regular block impacting the considered net fence. It is expressed in SEL (Service Energy Level) and MEL (Maximum Energy Level).

1.4.2.12. Reference slope

The reference slope is the slope downhill to the kit extended in the same direction to its maximum elongation. This slope is at least parallel to the block trajectory in the last metre before the impact as carried out in the test site. A deviation of $\pm 20^\circ$ is authorized.

1.4.2.13. Nominal height

The nominal height h_N is measured orthogonally to the reference slope and is the minimum distance between the upper rope and the connection line between the basis of the posts, before the impact. The producer can introduce in the commercial name of the product also a commercial height (in general the nominal height plus a tolerance). This commercial height is not a part of the verification.

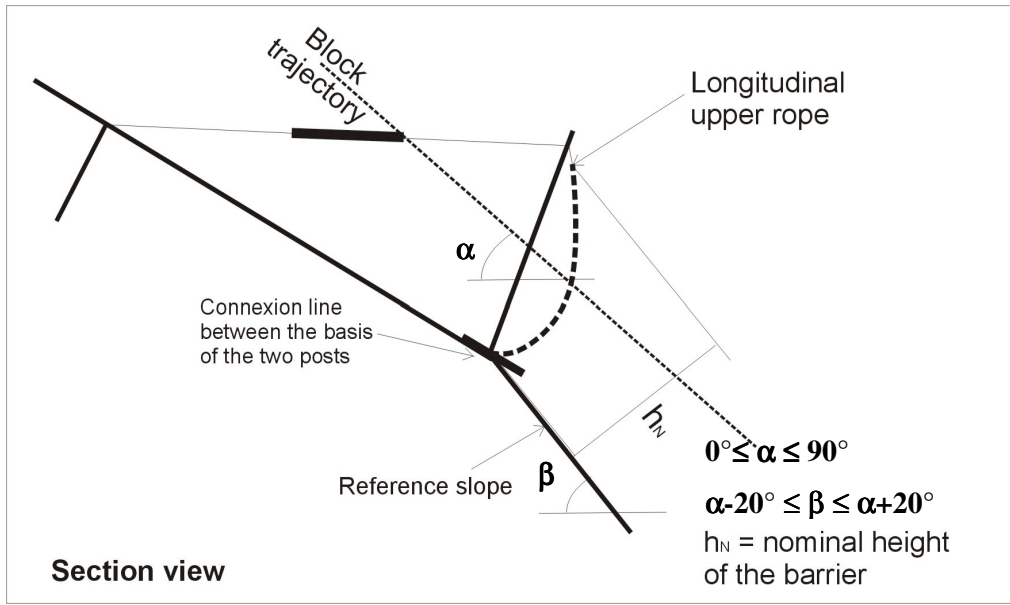

Fig 3. Nominal height of the barrier

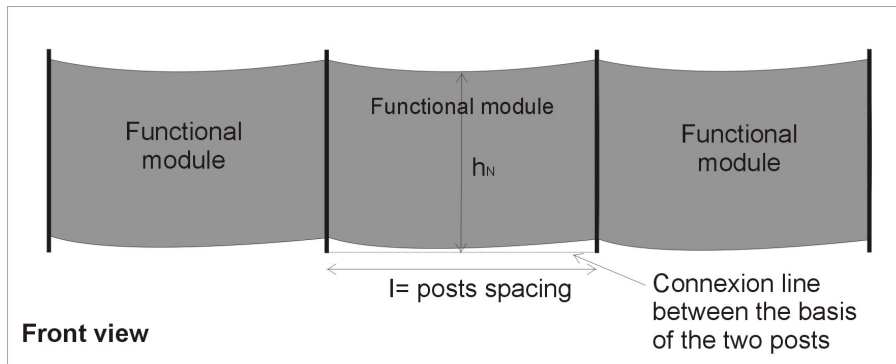

Fig 4. Front view of the kit

1.4.2.14. Elongation of the kit

The kit elongation is the downhill displacement measured parallel to the reference slope during the impact.

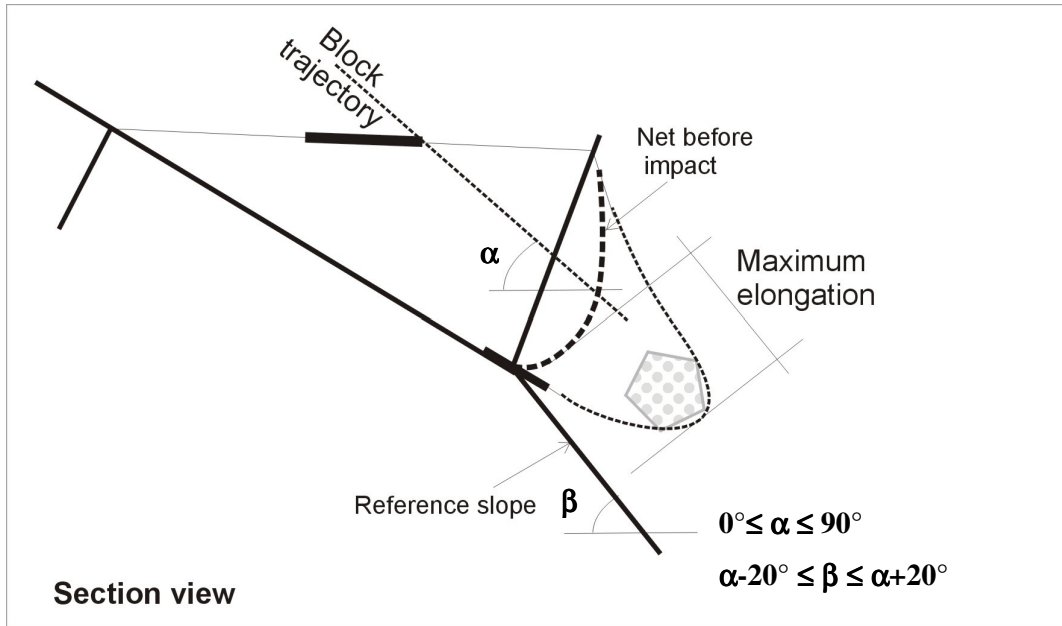

Fig 5. Maximum elongation

1.4.2.15. Braking time

The braking time is the time between the moment of the first contact between the block and the net and the moment of the maximum elongations of the net during the test.

1.4.2.16. Residual height

The residual height h_R is the minimum distance between the lower and the upper rope, measured orthogonally to the reference slope after the test without removing the block

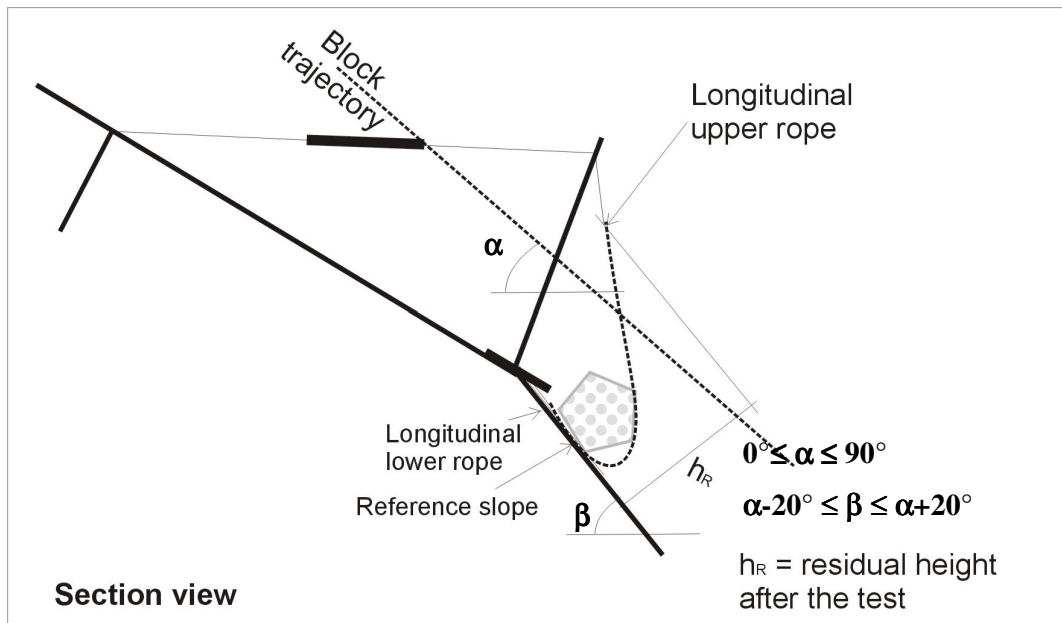

Fig 6. Residual height

1.5. Procedure in the case of a significant deviation from the ETAG

The provisions of this ETAG apply to the preparation and issue of European technical approvals in accordance with Art. 9.1 of the CPD and section 3.1 of the Common Procedural Rules.

In cases in which a certain provision of this ETAG is not or not fully applicable or a particular aspect of a kit, kit component, assembled system and/or intended use to be assessed is not or not sufficiently covered by the methods and criteria of the ETAG, the procedure of Art. 9.2 of the CPD and section 3.2 of the Common Procedural Rules applies with regard to the deviation or aspect concerned.

2 ASSESSMENT OF FITNESS FOR USE

2.1. Meaning of "fitness for use"

"Fitness for (the intended) use" of a construction product means that the product has such characteristics that the *works* in which it is to be incorporated *can*, if properly designed and built,

1. *satisfy* the Essential Requirements when and where such works are subject to regulations containing such requirements (CPD Art. 2.1) and
2. *be fit* for their intended use, account being taken of economy, *and* in this connection *satisfy* the Essential Requirements for an economically reasonable working life, if normally maintained (see CPD Annex I, sentence 1 and 2).

In the case of kits, "fitness for (the intended) use" refers to

- a) the characteristics of the assembled system (they must be such that the works in which the kit is to be incorporated, assembled, applied or installed, can, if properly designed and built, satisfy the Essential Requirements when and where such works are subject to regulations containing such requirements), as well as
- b) the characteristics of the components of the assembled system (they must be such that the assembled system, if properly assembled, has the characteristics referred to in clause a above).

2.2. Elements of the assessment of fitness for use

In the case of kits, the assessment of the fitness for use includes:

- the identification of the characteristics of the assembled system which are relevant to its fitness for use (in the following referred to as "regulatory system characteristics");
- the establishment of methods for the verification and assessment of the regulatory characteristics of the assembled system and the expression of the respective performances;
- the identification of regulatory characteristics to which the option "No Performance Determined" applies for the reason that in one or more Member States they are not relevant for the fulfilment of the requirements applicable to the works;
- the identification of regulatory characteristics for which limit values (threshold values) have to be respected for technical reasons;

and for the components of the assembled system, as far as relevant:

- the identification of the component characteristics which are relevant to the fitness for use of the assembled system (in the following referred to as "regulatory component characteristics");
- the establishment of methods for the verification and assessment of the regulatory component characteristics and the expression of the respective performances;
- the identification of regulatory component characteristics to which the option "No Performance Determined" applies for the reason that in one or more Member States they are not relevant for the fulfilment of the requirements applicable to the works;
- the identification of regulatory component characteristics for which limit values (threshold values) have to be respected for technical reasons.

2.3. Relationship of requirements to the characteristics of the assembled system and its components and methods of verification and assessment

The characteristics of the assembled system, methods of verification and assessment criteria which are relevant for the fitness of falling rock protection kits for the intended use referred to in 1.2 are given in Table 1.

Table 1 - Characteristics of the assembled system and methods of verification and assessment

Nr	System characteristic	Option "No Performance Determined"	Method of verification and assessment	Expression of system performance
Essential Requirement 1: Mechanical resistance and stability				
1	Energy absorption	No		Class
2	Deformation characteristics	No		Value, Class
3	Actions on foundations	No		Value
4	Durability	No		Value
Essential Requirement 2: Safety in case of fire				
Not relevant				
Essential Requirement 3: Hygiene, health and environment				
4	Release of dangerous substances	No		
Essential Requirement 4: Safety in use				
Not relevant				
Essential Requirement 5: Protection against noise				
Not relevant				
Essential Requirement 6: Energy economy and heat retention				
Not relevant				
General aspects relating to fitness for use				
Not relevant				

2.4. Characteristics of the assembled system which are relevant for the fitness for use

2.4.1. Energy absorption of the assembled system: Service Energy Level (SEL)

2.4.1.1. Method of verification

The Service Energy Level (SEL) of a falling rock protection kit is defined as the kinetic energy of a regular block impacting the considered net fence.

2.4.1.2. Method of assessing and judging

The falling rock protection kit passes the test for the SEL if it fulfils the following conditions:

The 1st SEL launch is passed if:

- The block is stopped by the kit
- No ruptures in the connection components (which remains connected to foundations) posts and ropes. The rupture of a connection component is defined as the complete separation of the component itself into two distinct parts. The opening of the mesh of the net shall not be two times bigger than the initial size of the mesh. Are excluded from the assessment elements like mechanical fuses which are designed to break under impact conditions. They shall be specifically listed in the installation document.
- The residual height of the kit after the test (without removing the block) is higher or equal to 70% of the nominal height. The measured value has to be declared.
- The block has not touched the ground until the kit has reached the maximum elongation during the test.

2nd SEL-launch is passed if:

- The block is stopped by the net fence.
- The block has not touched the ground until the kit has reached the maximum elongation during the test

No maintenance is allowed between the first and the second launch at SEL. The maximal elongation of the net fence during the SEL test shall be measured and provided in the test report.

2.4.2. Energy absorption of the assembled system: Maximum Energy Level (MEL)

2.4.2.1. Method of verification

The Maximum Energy Level (MEL) of a falling rock protection kit is defined as the kinetic energy of a regular block impacting the considered net fence with $MEL \geq \gamma \cdot SEL$ and $\gamma = 3$.

2.4.2.2. Method of assessing and judging

The falling rock protection kit passes the test for the MEL if it fulfils the following conditions:

- The net fence has stopped the block
- The block has not touched the ground until the kit has reached the maximum elongation during the test.

The maximal elongation of the net fence during the MEL test shall be measured and declared. The residual height of the net fence after the impact shall be measured and declared following the

classification laid down in point 2.5.1.2. A detailed description of damages of the kit has to be provided and included in the ETA.

2.4.3. Classification of the assembled system

2.4.3.1. Method of verification

The different classifications of falling rock protection kits are defined on SEL and MEL energy.

2.4.3.2. Method of assessing and judging

The retained level for SEL (in kJ) are 85, 170, 330, 500, 660, 1000, 1500 and superior to 1500 (see following table). The energy may not be less than the values given in the table below. For the last opened classification, the concerned value of SEL shall be declared. For classification 0, the SEL test is not required.

Energy level classification	0	1	2	3	4	5	6	7	8
SEL	-	85	170	330	500	660	1000	1500	>1500
MEL \geq	100	250	500	1000	1500	2000	3000	4500	>4500

Falling rock protection kit classes

A classification for residual height for MEL is also foreseen as follows:

Category A : Residual Height \geq 50 % nominal height

Category B: 30% nominal height < Residual Height < 50 % nominal height

Category C: Residual Height \leq 30 % nominal height

2.4.4. Deformation characteristics of the assembled system: Residual height

2.4.4.1. Method of verification

The residual height shall be measured after SEL and MEL tests according to figure 6.

2.4.4.2. Method of assessing and judging

The residual height of the kit after the SEL test (without removing the block) shall be higher or equal to 70% of the nominal height. The measured value shall be declared. The residual height of the net fence after the impact shall be measured and declared following the classification laid down in point 2.4.3.2.

2.4.5. Deformation characteristics of the assembled system: maximum elongation

2.4.5.1. Method of verification

The maximal elongation of the net fence during the MEL and SEL tests shall be measured according to figure 5.

2.4.5.2. Method of assessing and judging

The maximal elongation of the net fence during the MEL and SEL tests shall be declared.

2.4.6. Action on the foundations of the assembled system

2.4.6.1. Method of verification

The force shall be measured during all the time of impact.

2.4.6.2. Method of assessing and judging

The peak force shall be declared and the time-force diagrams shall be provided. The measured values shall be declared in the ETA.

2.4.7. Durability of the assembled system

2.4.7.1. Method of verification

The protection against corrosion shall be evaluated for the different parts of the interception structure, the support structure and the connection components of the kit.

2.4.7.2. Method of assessing and judging

The corrosion system (type, thickness...) shall be declared in the ETA.

2.4.8. Dangerous substances

2.4.8.1. Release of dangerous substances in the product

The product must be such that, when installed according to the appropriate provisions of the Member States, it allows for the satisfaction of the ER3 of the CPD as expressed by the national provisions of the Member States and in particular does not cause harmful emission of toxic gases, dangerous particles or radiation to the indoor environment nor contamination of the outdoor environment (air, soil or water).

2.4.8.2. Presence of dangerous substances in the product

The applicant shall submit a written declaration stating whether or not the product contains dangerous substances according to European and national regulations, when and where relevant in the Member States of destination, and shall list these substances.

2.4.8.3. Compliance with the applicable regulation

If the product contains dangerous substances as declared above, the ETA will provide the method which has been used for demonstrating compliance with the applicable regulations in the Member States of destination, according to the dated EU data-base (method(s) of content or release, as appropriate).

3 EVALUATION AND ATTESTATION OF CONFORMITY AND CE MARKING

3.1. System of attestation of conformity

According to the decision 2003/728/EC of the European Commission² the system of attestation of conformity given in table 2 applies.

Table 2 - System of attestation of conformity applicable to falling rock protection kit

Product(s)	Intended use(s)	Level(s) or class(es)	Attestation of conformity system(s)
Rockfall protection kits	In civil engineering works	Any	1

The system(s) of attestation of conformity referred to above is (are) defined as follows:

System 1: Certification of the conformity of the product by a notified certification body on the basis of:

- (a) Tasks for the manufacturer:
 - (1) factory production control;
 - (2) further testing of samples taken at the factory by the manufacturer in accordance with a prescribed test plan;
- (b) Tasks for the notified body:
 - (3) initial type-testing of the product;
 - (4) initial inspection of factory and of factory production control;
 - (5) continuous surveillance, assessment and approval of factory production control;

3.2. Tasks and responsibilities of the manufacturer and notified bodies

3.2.1. Tasks of the manufacturer

The ETA-holder shall exercise permanent internal control of the production. All the elements, requirements and provisions adopted by the ETA-holder shall be documented in a systematic manner in the form of written policies and procedures. This factory production control system shall ensure that falling rock protection kits are in conformity with the European Technical Approval (ETA).

The personnel involved in the production process shall be identified, sufficiently qualified and trained to operate and maintain the production equipment. Machinery equipment shall be regularly maintained and this shall be documented. All processes and procedures of production shall be recorded at regular intervals.

The ETA-holder shall maintain a traceable documentation of the production process from purchasing or delivery of raw or basic raw materials up to the storage and delivery of finished products.

² Official Journal of the European Communities L 262/34 of 14.10.2003

The factory production control system for the falling rock protection kits shall normally include relevant design specifications, including adequate drawings and written instructions and at least the following items:

- type and quality of all materials and components incorporated in the falling rock protection kits
- positions of components in the falling rock protection kits
- overall dimensions of falling rock protection kits
- installation of components and ancillary components
- markings for correct position and installation in the works, and special handling devices, when relevant
- packaging and transport instructions
- checks that the relevant design specifications for the production do exist, e.g. structural designs, construction details and manuals for installation

The production control system shall specify how the control measures are carried out, and at which frequencies.

FPC system that complies with EN ISO 9001 and that addresses the requirements of the ETA is recognised as a good technical basis for the evaluation of FPC requirements of the Directive.

Products that do not comply with requirements as specified in the ETA shall be separated from the conforming products and marked as such. The ETA-holder shall register non-compliant production and action(s) taken to prevent further non-conformities. External complaints shall also be documented, as well as actions taken.

3.2.1.1. Incoming material/products

Falling rock protection kits may consist of one or more of the following possibilities:

- components produced by the ETA-holder
- components produced by an independent manufacturer (supplier)
- components purchased by the ETA-holder on the open market

In any case, sufficient proof shall be established to show that permanent internal control takes place.

When materials/products are delivered for incorporation into the production process, verification of conformity with specifications in the ETA shall take place, with special attention for the following aspects:

- the steel of the different components is of the same type or class of the tested, assessed and certified kit with particular attention on elongation at breaking;
- posts materials are in conformity with relevant European standards, if any (e.g. EN 10025 for steel)
- the steel wire ropes and cables are in conformity with relevant European product standards (e.g. EN 12385)
- the nets and dissipating devices are in conformity with the ETA
- the clamps, bolts, are in conformity with the relevant standards

3.2.1.2. Documentation

In any case, documented verification of incoming material/products is considered necessary. A corresponding test plan should be agreed between notified body and ETA-holder. Where materials/components are not manufactured and tested by the supplier in accordance with agreed methods, or where the ETA-holder purchases materials/components on the open market, then where appropriate, they shall be subjected to suitable documented checks/tests by the ETA holder before acceptance.

The characteristics of incoming material and components, for which the supplier demonstrates documented compliance with a product specification, for an intended use that is appropriate for its use as a part of a falling rock protection kit, shall be considered satisfactory and need, except in justified doubt, no further checking, unless the test plan (see § 3.3) specifies differently.

For falling rock protection kits, the following components are regarded important for the kit to meet the essential requirements, and should therefore also be attested, in absence of CE marking and harmonized standards, by a 3rd party, following European or national standards:

- Posts
- Ropes and cables
- Dissipating devices
- Ring or cable net

For CE Marked components, the evidence of declaration of conformity and CE Certificates of conformity (where applicable) shall be verified by the ETA-holder at each delivery.

Other conformity certificates or declarations (e.g. manufacturer's declaration of conformity, inspection certificates in accordance with EN 10204, or other voluntary or national approved certificates), shall be checked regularly.

It is irrelevant where incoming materials and components are produced, as long as the requirements in this chapter are met.

3.2.1.3. Testing of samples taken at the factory

Both large and small companies produce these products and there is a wide variation in the materials used. Therefore a precise test plan can only be set up on a case-by-case basis.

In general, it is not necessary that the ETA-holder conducts for the purpose of FPC, field tests on complete falling rock protection kits. Tests on kit components, in some cases by indirect methods, are normally sufficient.

The following minimum information shall be recorded:

- date and time of manufacture
- type of product produced
- material specification
- all results of the verifications performed within the agreed upon test plan

3.2.1.4. Maintenance, checking and calibration of ETA-holder equipment

All testing equipment shall be maintained, calibrated and/or checked against equipment or test specimens traceable to relevant international or nationally recognised reference test specimens (standards). In case no such reference test specimens exist, the basis used for internal checks and calibration shall be documented. The ETA-holder shall ensure that handling, preservation and storage of test equipment is such that its accuracy and fitness for purpose is maintained.

When production is intermittent, the ETA-holder shall ensure that any test equipment which may be affected by the interruption is suitably checked and/or calibrated before use. The calibration of

all test equipment shall be repeated if any repair or failure occurs which could upset the calibration of the test equipment.

The corner stones of the actions to be undertaken by the manufacturer of falling rock protection kits in the procedure of attestation of conformity are laid down in Table 3. The actions to be undertaken by component manufacturer(s) or the kit manufacturer for the different components of the falling rock protection kit are laid down in Table 3a.

3.2.1.5. Test plan

The ETA-holder and the approval body issuing the ETA shall agree an FPC test plan. An agreed test plan is necessary as current standards relating to quality management systems (Guidance Paper B, EN ISO 9001, etc) do not ensure that the product specification remains unchanged, and they cannot address the technical validity of the type or frequency of checks / tests.

The validity of the type and frequency of checks/tests conducted during production and on the final product shall be considered. This shall include the checks conducted during manufacture on properties that cannot be inspected at a later stage, and for checks on the final product.

The following tables 3 and 3a show properties that should be controlled and minimum frequencies of control, but, for the purposes of FPC, the ETA-holder or component manufacturer may adopt alternative test methods, provided that they give sufficient assurance of the property controlled.

The tables below show the characteristics that need checking during FPC (as far as relevant). The results of these checks shall be registered by the ETA-holder. The test methods should correspond to those included in the technical specification, but different equipment may be used, as long as correlation can be established. The ETA-holder may also use external laboratories for these tests.

The tables below foresee minimum requirements. In many cases, constituent materials or components will be supplied by other manufacturers to the ETA-holder. In those cases, it is very likely that the supplier performs FPC on those constituent materials or components. If that is the case, those suppliers should submit the relevant records to the ETA-holder.

Depending on the nature of the constituent material or component and the evidence provided (e.g. supported by a third party certificate of conformity), the Approval body (and the Notified Body) will, in most cases, accept the evidence provided, although alternative verifications on the incoming products may then still be required (e.g. one verification per delivery). If no such evidence is available, the ETA-holder's FPC will be required to (at least) comply with the tables below.

Table 3 - Control plan for the manufacturer of the falling rock protection kit; corner stones

Nr	Subject/type of control <i>(product, raw/constituent material, component - indicating characteristic concerned)</i>	Test or control method <i>(refer to 3.2.3, 2.4 or 5.2)</i>	Criteria, if any	Minimum number of samples	Minimum frequency of control
Factory production control (FPC)					
1	Posts and plates (in case of steel) ³	tensile strength, elongation, yielding,		1 test per lot	

³ For other materials, similar characteristics shall be used with reference to existing European Standards. Concerned material characteristics for this intended use should be checked by 1 test per lot, but at least one per 50 posts.

		welding characteristics		For each post, welding shall be verified by visual check.	In addition, at least one test each year for each supplier shall be performed
		galvanization or other corrosion protection		3 tests per lot are requested with at least 3 tests per 50 posts/plates	
2	Cables / ropes	rope designation EN 12385-2 breaking force/ elongation, geometrical properties, galvanization or other corrosion protection		3 tests each reel or 50 panels (tests have not to be carried out on ring samples but taken from a panel)	
3	Dissipating device	force-displacements diagram, geometrical properties	Difference from declared value of activation force within 15%	At least 2 tests each year.	Every 100 pieces of the same type
4	Ring nets	breaking force, geometrical properties, wire breaking, elongation, galvanization or other corrosion protection		3 tests each delivery or every 50 panels of the same delivery.	
5	Clamps	Static load following relevant standards			Every 5000 clamps of the same type

Table 3a - Control plan for the component manufacturer or kit manufacturer; corner stones

Nr	Subject/type of control <i>(product, raw/constituent material, component - indicating characteristic concerned)</i>	Test or control method <i>(refer to 3.2.3, 2.4 or 5.2)</i>	Criteria, if any	Minimum number of samples	Minimum frequency of control
Factory production control (FPC)					
1	Posts and plates (in case of steel) ⁴	tensile strength, elongation, yielding,		According to relevant standard	
		welding characteristics			
		galvanization or other corrosion protection			
2	Cables / ropes	rope designation, breaking force/ elongation, geometrical properties, galvanization or other corrosion protection		According to relevant standard	
3	Dissipating device	force-displacements diagram, geometrical properties	Difference from declared value of activation force within 15%		Every 100 pieces
4	Ring nets	breaking force, geometrical properties, wire breaking / elongation, galvanization or other corrosion protection		3 tests each 50 panels	
5	Clamps	static load following relevant standards			Every 1000 clamps of the same type

3.2.2. Tasks of notified bodies

The corner stones of the actions to be undertaken by the notified body (bodies) in the procedure of attestation of conformity for falling rock protection kit are laid down in Table 4.

⁴ For other materials, similar characteristics shall be used with reference to existing European Standards. Concerned material characteristics for this intended use should be checked by 1 test per lot, but at least one per 50 posts.

Table 4 - Control plan for the notified body (bodies) for the kit manufacturer; corner stones

Type of control		Typical extent/frequency of control
AoC element (acc. to CPD Annex III.1)	Product, raw/constituent material, product component and characteristic concerned	
Initial type-testing of the product	Service Energy Level Test according to cl.2.4.1	when starting the production, or starting a new production line
	Maximum Energy Level Test according to cl.2.4.2	
	Deformations characteristics according to cl. 2.4.4/2.4.5	
	Action on foundations according to cl. 2.4.6	
	Tests on components (see Annex C)	
Initial inspection of factory and of factory production control	description with reference to the tasks	when starting the production, or starting a new production line
Continuous surveillance, assessment and approval of factory production control	description with reference to the tasks	once a year

3.3. CE marking and accompanying information

According to Council Directive 93/68/EEC⁵ the CE marking consists of the letters "CE" in the form laid down in the Directive, followed by the identification number of the notified certification body, where applicable. For products subject to Council Directive 89/106/EEC the identification number of the notified certification body shall be given for products to which systems 1+, 1 and/or 2+ of attestation of conformity apply.

The CE marking of falling rock protection kit shall be accompanied by the following information:

- the name and address of the producer (legal entity responsible for the manufacture),
- the last two digits of the year in which the CE marking was affixed,
- the number of the EC certificate of conformity for the product,
- the number of the European technical approval,
- Indication on the classification of the energy level and the category of the residual height for maximum energy level according to cl. 2.4.3.2 in this ETA Guideline

⁵ Official Journal of the European Communities L 220 of 30.8.1993

3.3.1. Example 1

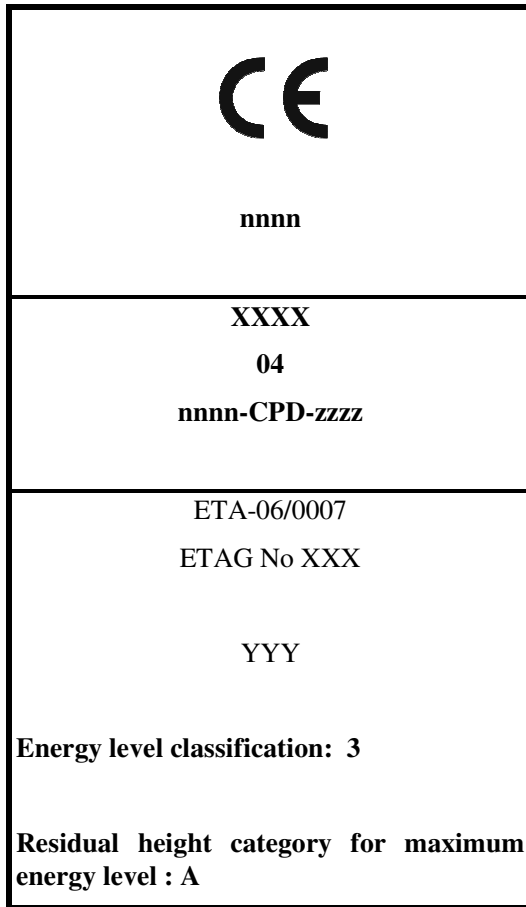

Letters “CE”

- Identification number of the notified body involved in the attestation of conformity (certification body)
- Name and address of the producer (legal entity responsible for the manufacture)
- Last two digits of the year in which the CE marking was affixed
- Number of the EC certificate of conformity (consisting of number of notified body involved in the A/C (“nnnn”) – CPD – number of EC certificate of conformity (“zzzz”))
- Number of the European Technical Approval
- ETAG number including date of publication

- Correspond to the definition of the product (including the possibility to use the trade mark)
- Class according to cl. 2.4.3.2 in the ETAG

- Category according to cl. 2.4.3.2 in the ETAG

3.3.2. Example 2

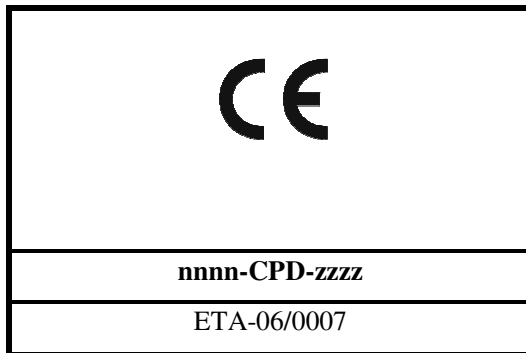

Letters “CE”

- Number of the EC certificate of conformity (consisting of number of notified body involved in the A/C (“nnnn”) – CPD – number of EC certificate of conformity (“zzzz”))
- Number of the European Technical Approval

3.3.3. Location of CE Marking

The CE Marking as example 1 shall be affixed on each post of the kit. It should be made of metal sheet or stamped on the post.

The CE Marking as example 2 shall be affixed on the packaging of the kit and of other components.

4 ASSUMPTIONS UNDER WHICH THE FITNESS FOR THE INTENDED USE IS ASSESSED

4.1. Manufacture of the kit

Not relevant

4.2. Packaging, transport, storage of the kit

The conditions for packaging, transport and storage of the falling rock protection kit shall be examined from the manufacturer terms of delivery.

The quality and sufficiency of these terms of delivery shall be assessed by the Approval Body, e.g. concerning the following aspects:

- protection against unfavourable environmental effects;
- protection against external damage during transport;
- intermediate storage at the construction site;
- easiness of transport (including helicopter transport);

4.3. Assembly and installation of the kit in the works

The conditions for installation of falling rock protection kits shall be taken from the manufacturer's installation guide.

The Approval Body shall verify the quality and sufficiency of the installation guide e.g. concerning the following aspects:

- the manufacturer shall provide all the key parameters to assembly the kit i.e. the clamp bolt torque, the number and type of clamps to be used for connecting the ropes, etc.
- the foundation types (for posts and for cables) and the types of connection of the foundations with the cables;
- the installation procedure of the energy dissipating devices;
- drawings showing the standard geometry of the kit and the installation scheme;
- the technical specification of all the components.

If the kit has been tested without additional layers, they may be added on site. On the contrary, if the kit has been tested with an additional layer, the latter is therefore part of the CE-marked kit.

The height of the barrier cannot be reduced in comparison with the tested kit and its height can not be raised up of more than 1 metre for tested height superior or equal to 4 metres and 0.5 metre for tested height less than 4 meters.

If for local reasons of the natural site it is necessary to have a different geometry from the test site geometry a specific design shall be provided. Forces acting in the structure should be evaluated to demonstrate the fitness for use of the falling rock protection kit. The producer, under its own responsibility, shall provide geometric tolerances in the installation book with special references to the spacing of the posts and the inclination of the main ropes.

4.4. Use, maintenance, repair

The guide shall provide a detail of the procedure to be used for changing and maintaining the components of the kit. The Approval Body shall verify that these procedures are provided in the manufacturer guide and are sufficiently described.

5 IDENTIFICATION OF THE KIT

5.1. Means of identification

The kit components shall be clearly identified. Where possible, reference to European or national EEA standards shall be made.

The chemical constitution and composition of the materials will be submitted by the kit manufacturer to the Approval Body, which will observe strict rules of confidentiality. Under no circumstances will such information be disclosed to any other party.

This composition shall be checked by the Approval Body on the basis of the declaration made by the manufacturer, and it will be documented by fingerprint whenever possible.

All components shall be specified, with appropriate tolerances and trade names of raw materials as far as they represent their chemical and physical properties.

The European Technical Approval is issued for the product on the basis of agreed data/information, deposited with the Approval Body, which identifies the product that has been assessed and judged. Changes to the product or production process, which could result in this deposited data/information being incorrect, should be notified to the Approval Body before the changes are introduced. The Approval Body name will decide whether or not such changes affect the ETA and consequently the validity of the CE marking on the basis of the ETA and if so whether further assessment or alterations to the ETA, shall be necessary.

All components shall be clearly specified. Where possible, reference to harmonised European Standards shall be made or to national standards within EEA. In the other cases, it is on the responsibility of the Approval Body to perform additional identification tests (see chapter 3 and annex C).

The Approval Body has to check that the material properties of the main components are those declared by the producer. This assessment should be done by testing or by an evaluation of the conformity certifications of the various components.

Some identification tests on the main components which greatly affect the performance of the kit (e.g. energy dissipating devices, single elements of the net and eventually other components, if needed, in the responsibility of the Approval Body) shall be performed.

The characteristics of the components of the kit may be verified, where appropriate, and should include:

- mechanical properties of components, eg. tensile strength, yield strength, elongation...
- dimensional specification of components
- the type and thickness of any protective coating
- chemical composition of raw materials

The test methods and identification procedure are described in annex C.

Table 5 - Characteristics of the components of the kit, methods of verification and criteria used for checking the component identity

Nr	Component	Component characteristic	Verification method:	Criteria for component identity:
1	Ropes	<ul style="list-style-type: none"> ▪ mechanical properties of components, eg. tensile strength, yield strength, elongation,etc ▪ dimensional specification of components ▪ type and thickness of any protective coating 	The test shall be carried out following the IEN 12385.	Sampling two specimen of each rope diameter from the falling rock protection kit
2	Energy dissipating devices	<ul style="list-style-type: none"> ▪ dimensional specification of components ▪ type and thickness of any protective coating ▪ energy absorbed during deformation 	The test shall be carried out by applying a traction to the specimen	Sampling one specimen of “energy dissipating device” of the falling rock protection kit.
3	Net elements	<ul style="list-style-type: none"> ▪ mechanical properties of components, eg. tensile strength, yield strength, elongation,etc ▪ dimensional specification of components ▪ type and thickness of any protective coating ▪ type of assembly 	The test shall be carried out by applying a traction to the specimen	Sampling one specimen from the net of the falling rock protection kit.
4	Posts	<ul style="list-style-type: none"> ▪ mechanical properties of components, eg. tensile strength, yield strength, elongation,etc ▪ dimensional specification of components ▪ the type and thickness of any protective coating 	Tests on posts or producer certificate	Sampling the posts of the net OR by an evaluation of the conformity certifications of the various components.

5.2. Components of the assembled system and their characteristics which are relevant for identification checking

5.2.1. Ropes

5.2.1.1. Mechanical properties of components

5.2.1.1.1. Method of verification

The test shall be carried out following the norm IEN 12385.

5.2.1.1.2. Criteria for component identity

Two samples of each rope diameter should be taken from the kit.

5.2.1.2. Dimensional specification of components

5.2.1.2.1. Method of verification

All the diameter and length of the kit ropes shall be measured.

5.2.1.2.2. Criteria for component identity

All the ropes should be measured with callipers and with a metric tape or using an equivalent system.

5.2.1.3. Type and thickness of any protective coating

5.2.1.3.1. Method of verification

Random sampling of the ropes of the net.

5.2.1.3.2. Criteria for component identity

Test on some randomly chosen ropes on the net or by an evaluation of the conformity certifications.

5.2.2. Energy dissipating devices

5.2.2.1. Energy absorbed during deformation

5.2.2.1.1. Method of verification

The test shall be carried out following the scheme of Annex C

5.2.2.1.2. Criteria for component identity

One samples of the energy dissipating device should be taken from the kit

5.2.2.2. Dimensional specification of components

5.2.2.2.1. Method of verification

The diameter and the length of the energy dissipating devices ropes and/or elements shall be measured

5.2.2.2.2. Criteria for component identity

The size of the element should be measured randomly with callipers, with a metric tape or with an equivalent system

5.2.2.3. Type and thickness of any protective coating

5.2.2.3.1. Method of verification

Random sampling of energy dissipation device or by an evaluation of the conformity certifications

5.2.2.3.2. Criteria for component identity

Declaration of the producer and eventual test on some randomly chosen ropes on the net

5.2.3. Net elements

5.2.3.1. Mechanical properties of components

5.2.3.1.1. Method of verification

The test shall be carried out following the scheme of Annex C

5.2.3.1.2. Criteria for component identity

One sample of the net element should be taken from the kit. The specimen is a portion of a net of the falling rock protection kit.

5.2.3.2. Dimensional specification of components

5.2.3.2.1. Method of verification

The diameter of the net ropes and the net size shall be measured.

5.2.3.2.2. Criteria for component identity

The size of the ropes shall be measured randomly with callipers, with a metric tape or with an equivalent system.

5.2.3.3. Type and thickness of any protective coating

5.2.3.3.1. Method of verification

Random sampling of one net element or by an evaluation of the conformity certifications.

5.2.3.3.2. Criteria for component identity

Declaration of the producer and eventual test on some randomly chosen ropes on the net.

5.2.3.4. Type of assembly

5.2.3.4.1. Method of verification

Test of one element of the net. The specimen is a portion of a net of the falling rock protection kit.

5.2.3.4.2. Criteria for component identity

The test shall be carried out following the scheme of Annex C.

5.2.4. Post

5.2.4.1. Mechanical properties of components

5.2.4.1.1. Method of verification

Test on the material or by an evaluation of the conformity certifications.

5.2.4.1.2. Criteria for component identity

Declaration of the producer and eventual test on some randomly chosen samples

5.2.4.2. Dimensional specification of components

5.2.4.2.1. Method of verification

The diameter and the size of the post and of the hinge shall be measured

5.2.4.2.2. Criteria for component identity

The size of the elements should be measured randomly with callipers, with a metric tape or with an equivalent system

5.2.4.3. type and thickness of any protective coating

5.2.4.3.1. Method of verification

Random sampling of the post material or by an evaluation of the conformity certifications.

5.2.4.3.2. Criteria for component identity

Declaration of the producer and eventual test on some randomly chosen samples

6 FORMAT OF ETAS ISSUED ON THE BASIS OF THE ETAG

European technical approvals issued on the basis of this ETAG shall be in accordance with the ETA format given in the Addendum to the ETAG.

Specifically, the ETA shall include the determined values of the harmonised characteristics according to table 1 and concerned descriptions with respect to failure after impacts:

- Energy level classification according to cl. 2.4.3
- Service energy level (n kJ) according to cl. 2.4.1
- Measured value for residual height (in m) after 1st SEL launch
- Description about fulfilment of conditions with respect to ruptures and opening of the mesh after 1st SEL launch according to cl. 2.4.1.2
- Declaration of maximum elongation (m) during both SEL tests
- Maximum energy level (in kJ) according to cl. 2.4. 2
- Measured value for residual height (in m) after MEL launch
- Category of residual height after MEL launch according to cl. 2.4.3
- Declaration of maximum elongation (m) during MEL test
- Description about damages of the kit after the MEL test
- Measured values of peak forces (including time-force diagrams) with respect to actions on foundations
- Release of dangerous substances
- Durability

7 REFERENCE DOCUMENTS

- EC/EOTA documents:

[1] CPD: Directive relating to construction products. Council Directive of 21 December 1988 on the approximation of laws, regulations and administrative

provisions of the Member States relating to construction products (89/106/EEC) taking account of the modified provisions (93/68/EEC).

[2] ID No 1 (Mechanical Resistance and Stability): Council Directive 89/106/EEC, Construction Products Interpretative Documents.

[3] ID No 3 (Hygiene, Health and the Environment): Council Directive 89/106/EEC, Construction Products Interpretative Documents.

[4] EC Guidance Paper A : The designation of approved bodies in the field of the construction products directive, CONSTRUCT 95/149 Rev. 2.

[5] EC Guidance Paper B : The definition of factory production control in technical specifications for construction products, CONSTRUCT 95/135 Rev 1.

[6] EC Guidance Paper C : The treatment of kits and systems under the construction products directive, CONSTRUCT 96/175 Rev. 2.

[7] EC Guidance Paper D : CE-marking under the construction products directive, CONSTRUCT 97/220 Rev. 5.

[8] EC Guidance Paper E : Levels and classes in the Construction Product Directive, CONSTRUCT 99-337 Rev.1.

[9] EC Guidance Paper F : Durability and the Construction Products Directive, CONSTRUCT 99/367.

[10] EC Guidance Paper H: A harmonized approach relating to dangerous substances under the Construction Product Directive, CONSTRUCT 99/363 Rev.1.

[11] EC Guidance paper K: The attestation of conformity systems and the role and tasks of the notified bodies in the field of the construction products directive

[12] ETA-format : Commission decision of 22nd July 1997 on the general format of European Technical Approvals for construction products, 97/571/EC, O.J. No L 236/7 to 13, 27th August 1997.

[13] The provision of data for assessments leading to ETA, 31st EOTA Technical board, 20-21 January 1999.

- European Standards:

[14] EN ISO 9001 Quality systems : Model for quality assurance in design, development, production, installation and servicing.

[15] EN ISO 9002 Quality systems : Model for the quality assurance in production, installation and servicing.

[16] EN 12385-1:2002, Steel wire ropes – Safety – Part 1: General requirements.

[17] EN 12385-2:2002, Steel wire ropes – Safety – Part 2: Definitions, designation and classification.

[18] EN 12385-3:2004, Steel wire ropes - Safety - Part 3: Information for use and maintenance

[19] EN 12385-4:2002, Steel wire ropes - Safety - Part 4: Stranded ropes for general lifting applications

[20] EN 10025:1993, Hot-rolled products of non-alloy structural steels – Technical delivery conditions.

- Supporting documents:

- [21] ENV 1991-1:1994, Eurocode 1 : Basis of design and actions on structures – Part 1 : Basis of design.
- [22] ENV 1992-1-1:1991, Eurocode 2 : Design of concrete structures – Part 1-1 : General rules and rules for buildings.
- [23] ENV 1993-1-1:1992, Eurocode 3 : Design of steel structures – Part 1-1 : General rules and rules for buildings.
- [24] ENV 1994:1992, Eurocode 4 : Design of composite steel and concrete structures.
- [25] ENV 1997:1999, Eurocode 7 : Geotechnical design.
- [26] EN 288-2:1992, Specification and qualification of welding procedures for metallic materials – Part 2 :Welding procedure specifications for arc welding.
- [27] EN 288-3:1992, Specification and qualification of welding procedures for metallic materials – Part 3 : Welding procedure tests for the arc welding of steels.
- [28] EN 499:1994, Welding consumables - Covered electrodes for manual metal arc welding of non alloy and fine grain steels - Classification.
- [29] EN 1537:1999, Execution of special geotechnical work : Ground anchors.
- [30] EN 288-1:1992, Specification and qualification of welding procedures for metallic materials – Part 1 : General rules for fusion welding.
- [31] NV 10080:1995, Steels for reinforcement of concrete - Weldable ribbed reinforcing steels B500 – Technical delivery conditions for bars, coils and welded fabric.
- [32] EN 10113-1:1993, Hot-rolled products in weldable fine grain structural steels – Part 1 : General delivery conditions.
- [33] EN 10113-2:1993, Hot-rolled products in weldable fine grain structural steels - Part 2 : Delivery conditions for normalized rolled steels.
- [34] EN 10113-3:1993, Hot-rolled products in weldable fine grain structural steels - Part 3 : Delivery conditions for thermo mechanically rolled steels.
- [35] EN 10149-1, Hot rolled flat products made of high yield strength steels for cold forming – Part 1 : General delivery conditions.
- [36] EN 10149-2, Hot rolled flat products made of high yield strength steels for cold forming – Part 2 : Delivery conditions for thermomechanically rolled steels.
- [37] EN 10149-3, Hot rolled flat products made of high yield strength steels for cold forming – Part 3 : Delivery conditions for normalized or normalized rolled steels.
- [38] EN 10210-1:1994, Hot finished structural hollow sections of non-alloy and fine grain structural steels – Part 1 Technical delivery requirements .
- [39] EN 10210-2:1997, Hot finished structural hollow sections of non-alloy and fine grain structural steels – Part 2 Tolerances, dimensions and sectional properties.
- [40] EN 10219-1:1997, Cold formed welded structural hollow sections of non-alloy and fine grain steels – Part 1 :Technical delivery requirements.
- [41] EN 10219-2:1997, Cold formed welded structural hollow sections of non-alloy and fine grain steels – Part 2 : Tolerances, dimensions and sectional properties.
- [42] EN 10264-2, Steel wire and wire products – Steel wire for ropes – Part 2: Cold drawn non-alloyed steel wire for ropes for general applications.
- [43] EN 10083 Quenched and tempered steels

[44] EN 10088 Stainless steels

[45] EN ISO 6988, metallic and other non organic coatings – sulfur dioxide test with general condensation of moisture.

[46] ISO 9227 Corrosion test in artificial atmospheres. Salt spray test

ANNEX A

IMPACT TEST METHOD

This annex describes the impact test method procedure of the falling rock protection kit.

A.1 Test site

The test site is a structure, which shall be able to accelerate a concrete block to the test speed and to impact it onto the net fence with the necessary precision. The slope downhill to the kit is at least parallel to the block trajectory in the last metre before the impact. Tolerance is defined on Fig. A-1 (β angle). This slope is defined as the reference slope.

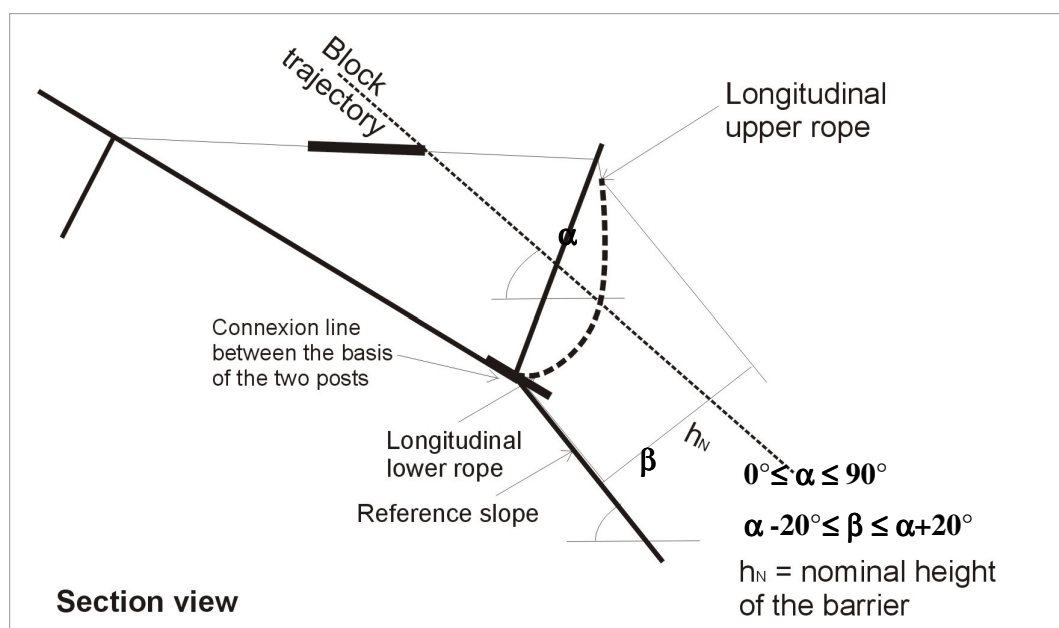

Fig A-1. Test site slope

A.2 Test equipment

- Kit installation

Three functional modules shall be used for the tests (4 posts). The producer shall decide the installation geometry from the foreseen block trajectory in the test site in accordance with the installation manual. The installation of the falling rock protection kit is in charge of the producer following the installation manual with the supervision of the Approval Body. Recording and measurement equipments are of the responsibility of the Approval Body. The anchorages design shall be provided the kit producer who shall formally accept the foundations structure before all the tests.

- Block

The block is made of plain/reinforced concrete and its shape is a polyhedra defined in Figure A-2.

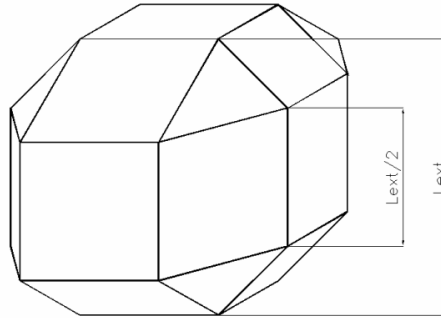

Fig A-2. Shape of the block

The density of the block shall be between 2500 kg/m³ and 3000 kg/m³. In case of added steel, it shall be installed in a symmetric way to allow the coincidence between the centre of gravity and the geometrical centre of the block.

The maximum size of the block (L_{ext}) shall be 3 times smaller than the nominal height of the kit.

A.3 Test conditions

The trajectory of the block is inscribed in a vertical plane orthogonal to the connection line between the bases of the posts of the falling rock protection kit. It can be inclined or vertical.

The average velocity of the block within the last 1 metre from the contact point with the net shall be greater or equal to 25 m/s.

The test consists in the launching of blocks described in A.2 into the falling rock protection kit measuring the speed of the block before the impact and therefore determining the impact energy of the block. The value of the impact energy is equal to the kinetic energy of the block, given by:

$$E_c = \frac{1}{2} \cdot m \cdot V_{impact}^2$$

where:

- V_{impact} is the speed of the impacting block evaluated in the last metre before the impact;
- m is the mass of the impacting block.

Note:

- Kinetic energy $\frac{1}{2}m(V_{impact}^2) =$ Potential energy $mg\Delta h - W_f$
- $V_{initial}=0$
- $\Delta h = Z_{impact} - Z_{initial}$
- $W_f =$ work of friction forces

A.4 Nominal and residual height, maximum elongation

The nominal height h_N is measured orthogonally to the reference slope and is the minimum distance between the upper rope and the connexion line between the posts. The result of the measurement shall be rounded to the nearest centimetre.

The residual height h_R is measured orthogonally to the reference slope after a test without removing the block and is the minimum distance between the lower and the upper rope. The result of the measurement shall be rounded to the nearest centimetre.

The maximum elongation is measured parallel to the reference slope, taking into account the maximum deflection of the net during the test, using video camera. The result of the measurement shall be rounded to the nearest centimetre.

A.5 Test procedure

The test procedure is based on successive tests at two different energy level: Service Energy Level (SEL) and one Maximum Energy Level (MEL). The MEL value shall be greater or equal to $3 \times (\text{nominal SEL})$ (see table 2). The MEL value shall be chosen by the producer before the test.

A.6 Service Energy Level (SEL) test

The Service Energy Level (SEL) test is carried out with two launches of a block into the falling rock protection kit at the same Kinetic Energy. The objective of this test is to see if the kit is able to accept successive impacts and the reduction of the useful height of the barrier is limited within an acceptable value.

Position of the 1st SEL-launch: in the centre of the middle functional module.

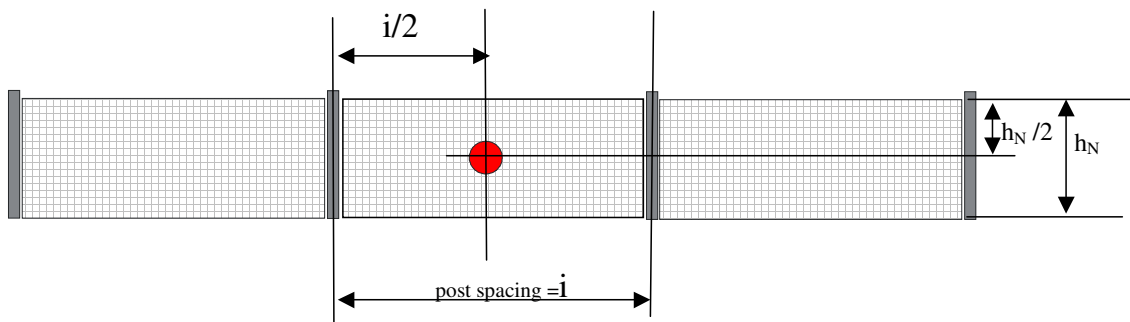

Fig A-3. Location of impact at 1st SEL-launch

The block is removed after the first launch.

Position of the 2nd SEL-launch: Within the centre functional module inside the residual height h_R of the kit, which has been obtained after the first SEL, launch.

The kinetics parameters (block speed and mass) are the same than for the first launch within the tolerances due to the deformation of the kit after the first launch.

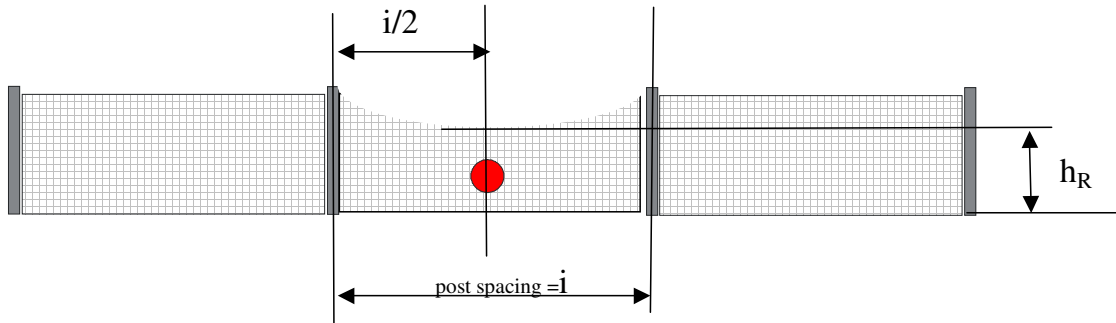

Fig A-4. Location of impact at 2nd SEL-launch

A.7 MAXIMUM ENERGY LEVEL (MEL) TEST

The test is carried out with one single launch of a block into the falling rock protection kit. The objective of this test is to characterize the maximum capacity of the falling rock protection kit. The MEL test will also give the residual height and the maximum elongation of the fence toward the protected objects and therefore allow for a safe positioning of the kit (minimum distance between the kit and protected objects).

The MEL test may be carried out in the same kit used for SEL testing after being repaired or in a new kit. It is up to the producer to choose between these two opportunities before the MEL test.

Position of the MEL-launch : in the centre of the middle functional module

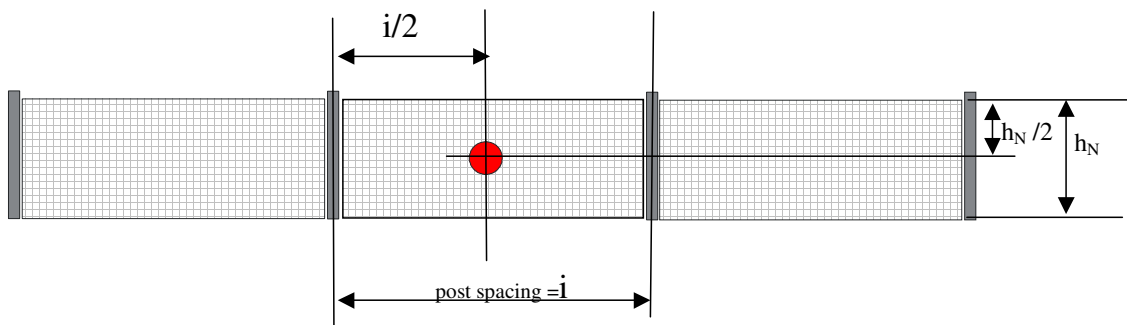

Fig A-5. Location of impact at MEL

The maximal elongation of the net fence during the MEL test and the residual height shall be measured and declared. A detailed description of damage to the kit (including residual height) has to be provided.

A.8 RECORDING TEST DATA

The following test characteristics shall be recorded, both for SEL and MEL test

pre-test data

- mass of the block
- Nominal height
- photographs of the position and construction of the falling rock protection kit
- geometric parameters of the falling rock protection kit
- Mechanical and physical characteristics of components (see 2.6)

test data

- block speed evaluated in the last metre before the impact
- block trajectory
- maximum elongation of the net fence
- photographic records by means to give a complete record of the kit behavior, including deformation, deflections, braking time and proof of no ground contact before the maximum elongation to be reached.
- Forces applied to the foundations

post test data

- residual height
- Description and photographic records of damages of the tested falling rock protection kit according to annex B

Block speed measurements shall be done with high-speed video-measurement at a minimum of 100 frames per second or other devices with at least the same precision and with adequate reference length.

Photographic or video cameras shall be sufficient to clearly describe barrier behaviour and block motion before and during the test.

At least, one high-speed video camera is advised to be used for speed measurements.

The need for additional camera layouts should be considered to cover areas of special interest.

Measures on anchorage and ropes shall be adapted to the specific falling rock protection kit under test. At least 3 measures shall be performed on main ropes linked to the centre functional module. The decision shall be carried out case by case by the Approval Body. The force shall be measured during all the test. The peak force shall be declared and the time-force diagrams shall be provided. The recording of the force shall be at least 1000 measurements per second.

Height measurements shall use topographic systems (non-contact optical measurements) or gauging tape. For maximum elongation during impact, video shall be used.

The mass and size of the block shall be measured before each test using an adequate dynamometer. A photo of the block shall be taken before the test.

A.9 PRECISION AND TOLERANCES

The precision of the launch with reference to the geometrical impact point of the centre of gravity of the block in the test procedure is a one-metre diameter circle around the optimal impact point for the 1st SEL launch and MEL test.

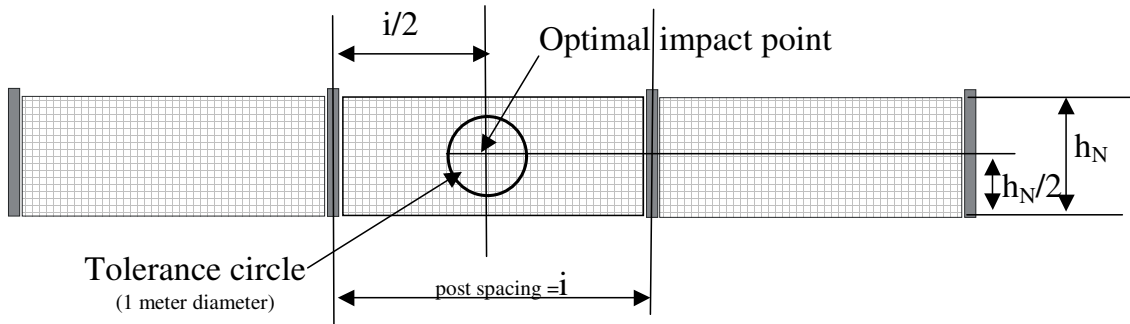

Fig A-6: Tolerance for impact point

The minimum accuracy of the mass measurements shall be $\pm 3\%$.

The overall accuracy of the speed measurements shall be $\pm 5\%$.

The test procedure should allow to give an energy value measured with an accuracy of $\pm 7\%$.

Forces measurements shall be performed with devices calibrated at least once a year.

All the distances shall be measured with an accuracy of $\pm 1\%$ for static measures and $\pm 5\%$ for dynamic measures

A tolerance of $\pm 5^\circ$ is authorised for the impact angle between the foreseen trajectory and the effective trajectory of the block in the test site.

A.10 TEST REPORT

Detailed description and design specification of the tested falling rock protection kit shall be included in the test report to enable verification of conformity of the installed system to be tested.

Pre-test, test and post-test data shall be included in the test report through photos, videos, drawings and general description as described in annex B.

ANNEX B

TEST REPORT FORMAT

General

EOTA Body: _____

Approved body: _____

Person in charge for approved body: _____

Manufacturer: _____

Product specification: _____

Product Name: _____

Contents

Chapter 1: documentation of the tested kit

Chapter 2: execution of the test

Chapter 3: post test data

CHAPTER 1: DOCUMENTATION OF THE TESTED KIT

1.1 Geometry of the system:

1.1.1 System sketches

1.1.1.1 Frontal view

1.1.1.2 Vertical cross section

1.1.1.3 Horizontal projection

1.1.1.4 System sketches of details (i. E. ground plate, connection of post/ground plate, energy dissipation device etc.)

1.1.2 Nominal Height of Barrier

1.1.3 Height and Inclination of Support Structure

1.1.4 Length of functional module (Posts spacing)

1.2 Description of Components

1.2.1 Support Structure

1.2.1.1 Material

1.2.1.2 Dimension

1.2.1.3 Mechanical properties

1.2.2 Ground plate

1.2.2.1 Material

1.2.2.2 Dimensions

1.2.3 Interception structure (principle net)

1.2.3.1 Description

1.2.3.2 Geometry

1.2.3.3 Diameter of wires/cables/clamps etc.

1.2.3.4 Material Properties

1.2.4 Connecting components (i. e. upper and lower longitudinal ropes)

1.2.4.1 Number of ropes

1.2.4.2 Diameter

1.2.4.3 Material

1.2.4.4 Mechanical properties

1.2.5 Energy dissipation device

1.2.5.1 Description

1.2.5.2 Number

1.2.5.3 Positions

1.2.5.4 Material

1.2.5.5 Mechanical properties

1.2.6 Characteristics of connection (Clamps, shackles etc.)

- 1.2.6.1 Description
- 1.2.6.2 Number
- 1.2.6.3 Positions
- 1.2.6.4 Material
- 1.2.6.5 Mechanical properties

CHAPTER 2 : IDENTIFICATION TESTS :

CHAPTER 3: TEST EXECUTION

3.1 Measurement devices and calibration

3.1.1 Dynamometers

- 3.1.1.1 Position on test site
- 3.1.1.2 Technical description
- 3.1.1.3 Evidence of calibration

3.1.2 High-speed video camera

- 3.1.2.1 Evidence of calibration
- 3.1.2.2 Distortion of camera (horizontal/vertical)

3.1.3 Additional Video Equipment

- 3.1.3.1 Technical description of used equipment

3.2 Block characteristics

3.2.1 Weight

- 3.2.1.1 Dynamometer
 - Description of dynamometer
 - Actual calibration sheet

3.2.1.2 Result of weight measurement

3.2.2 Dimensions (Shape see Annex A, Fig. 8)

L_{Ext} of the block

3.2.3 Photos of test block

CHAPTER 4 POST TEST DATA

4.1 SEL Test

4.1.1 Trajectory

4.1.1.1 SEL 1

- Effective trajectory
- Location of impact

- Proof of no ground contact
- 4.1.1.2 SEL 2
 - Effective trajectory
 - Location of impact
 - Proof of no ground contact
- 4.1.2 Measured dynamic data
 - 4.1.2.1 SEL 1
 - Forces on ropes
 - Speed of the block
 - Maximum elongation
 - 4.1.2.2 SEL 2
 - Forces on ropes
 - Speed of the block
 - Maximum elongation
- 4.1.3 Calculation of test data
 - 4.1.3.1 Energy of the block (SEL 1)
 - 4.1.3.2 Energy of the block (SEL 2)
- 4.1.4 Measurement of geometry of tested system after launch
 - 4.1.4.1 SEL 1
 - Residual height
 - Amount of activation (travel) of energy-dissipation devices
 - 4.1.4.2 SEL 2
 - Residual height
 - Amount of activation (travel) of energy-dissipation devices
- 4.1.5 Documentation of damages (verbal description and photo-documentation)
 - 4.1.5.1 SEL 1
 - Interception structure
 - Supporting structure
 - Connection structure
 - 4.1.5.2 SEL 2
 - Interception structure
 - Supporting structure
 - Connection structure
- 4.1.6 Photo-documentation
 - 4.1.6.1 SEL 1
 - Frontal view of kit
 - Side view of kit

- Each system component

4.1.6.2 SEL 2

- Frontal view of kit

- Side view of kit

- Each system component

4.2 MEL Test

4.2.1 Trajectory

- 4.2.1.1 Effective trajectory

- 4.2.1.2 Location of impact

- 4.2.1.3 Proof of no ground contact

4.2.2 Measured dynamic data

- 4.2.2.1 Speed of the block

- 4.2.2.2 Forces on ropes

- 4.2.2.3 Maximum elongation

4.2.3 Calculation of test data

- 4.2.3.1 Energy of the block

4.2.4 Measurement of geometry of tested system after launch

- 4.2.4.1 Residual height

- 4.2.4.2 Amount of activation (travel) of energy-dissipation devices

4.2.5 Documentation of damages (verbal description and Photo-documentation)

- 4.2.5.1 Interception structure

- 4.2.5.2 Supporting structure

- 4.2.5.3 Connection structure

4.2.6 Photo-documentation

- 4.2.6.1 Frontal view of kit

- 4.2.6.2 Side view of kit

- 4.2.6.3 Each system component

ANNEX C

IDENTIFICATION TESTS

For specific details and elements for which a non-standardized test exists, the Approval Body can set up specific test procedures case by case, which will be part of the test report. Identification tests are performed according to clause 5.

C.1 TEST ON ROPES

C.1.1 Test specimen

The specimen are portions of the main ropes of the falling rock protection kit (2 samples for each diameter).

C.1.2 Test procedure

The test shall be carried out following the IEN 12385.

C.2 TEST ON ENERGY DISSIPATING DEVICES

C.2.1 Test specimen

The specimen is one “energy dissipating device” part of the falling rock protection kit.

The producer shall provide all the geometrical and mechanical properties of the device and a drawing before the SEL test.

C.2.2 Test procedure

C.2.2.1 Geometrical properties

Before the SEL and MEL tests a geometrical check of the “energy dissipating device” shall be carried out and the measurements are reported in the test report.

C.2.2.2 Laboratory test

The “energy dissipating device” to be tested is mounted in a calibrated test traction rig and a slight tension is given to stabilize the system, then the force is reduced again to zero before the test starting.

After the “energy dissipating device” is tensioned by the test machine with a recommended displacement speed of 2mm/s.

The testing machine shall be of class 1.

The total elongation of the device shall correspond to its maximum elongation (if lower than 1m) or to an elongation of 1m.

C.2.3 Measurements and observations

The following measurements and observations shall be made and recorded:

- compliance checking of the geometric properties of the device;
- measurement and diagram of the applied force and obtained elongation;
- location and mode of eventual failure.

C.3 TEST ON NET ELEMENTS

Due to the large number of possible net types the following document refers only to the most used types. A different test procedure may be used for specific products following the decision of the Approval Body.

The specimen is a portion of a net of the falling rock protection kit.

If possible, the specimen is taken from the kit after the test, in a lateral module of the kit not stressed by the MEL test (the position is chosen by the Approval Body).

C.3.1 Ring nets

C.3.1.1 Test specimen

The test specimens are chains of three rings. The connection of the single ring element with the other rings in the net assembly shall be reported in the test report.

During the taking of the sample there should be no damage to the sample itself.

C.3.1.2 Test procedure

The chain of three rings is mounted in a calibrated test traction rig and it is connected to the machine with two circular elements of 50mm diameter, not less than 4 times the diameter of the strand.

Before the test a slight tension is given to stabilize the system, then the force is reduced again to zero before the test starting.

The chain of three rings is tensioned by the test machine with a recommended displacement speed of 2 mm/s, until breaking.

The test traction rig shall be of class 1.

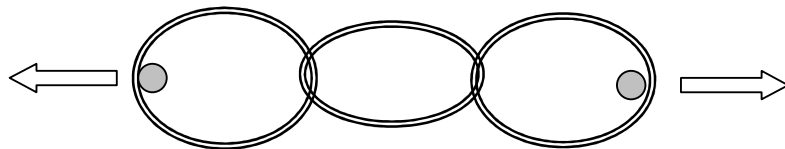

Figure C-1 Scheme of the test on net rings

C.3.1.3 Measurements and observations

The following measurements and observations shall be made and recorded:

- compliance checking of the geometric properties of the ring

- measured maximum breaking force
- location and mode of failure.

C.3.2 Cable nets joined with clamps and crossing ropes

C.3.1.1 Test specimen

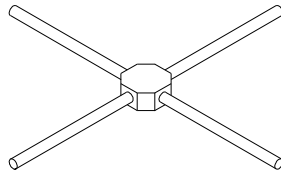

Figure C-2 Example of a net element around a clamp.

The test samples are formed by 3 net elements around the clamp and 3 rope samples. Each rope length around the clamp shall be of a length of 150mm

C.3.1.2 Test procedure

C.3.1.2.1 Test on ropes

The ropes shall be tested following the procedures described in C1

C.3.1.2.2 Test on clamps

For the test the element is mounted in a calibrated test traction rig. The test should allow the evaluation of the slipping force of the rope through the clamp.

The testing machine shall be of class 1

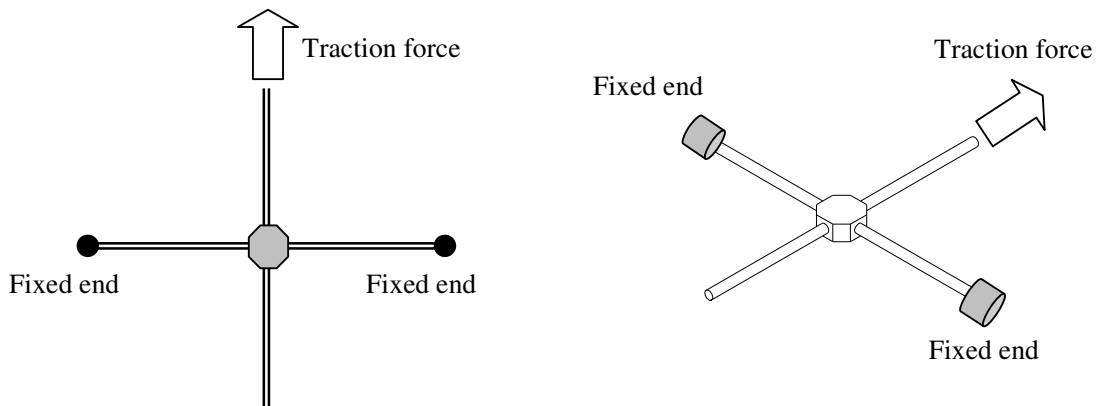

Figure C-3 Scheme of the test on the clamp

C.3.1.3 Measurements and observations

The following measurements and observations shall be made and recorded:

- compliance checking of the geometric properties of the net element
- measured maximum slipping force in the clamp
- maximum breaking force of the ropes constituting the net.

C.3.3 Other types of nets

Due to the great possible variability of the nets specific characterization test shall be decided case by case by the Approval Body and will be part of the test report .

C.4 POSTS

If needed, as stated in cl.5.2.4, tests on post samples may be done, to evaluate the physical and mechanical properties, using the relevant European Standard (e.g. EN 10025 in case of steel).

ADDENDUM: FORMAT OF ETAS ISSUED ON THE BASIS OF ETAG
...(number) [PART ...(number)]

Cover page of the ETA

*according to Document 5.1 (new ETA), Document 5.2 (modified ETA) or
Document 5.3 (ETA with extended period of validity), as relevant.*

Page 2 of the ETA

with headline Page 2 of ETA-xx/xxxx, issued on dd.mm.yyyy[, validity extended on dd.mm.yyyy]

I LEGAL BASES AND GENERAL CONDITIONS

- 1 This European Technical Approval is issued by *...(name of approval body)* in accordance with:
- Council Directive 89/106/EEC of 21 December 1988 on the approximation of laws, regulations and administrative provisions of Member States relating to construction products⁶, modified by Council Directive 93/68/EEC⁷ and Regulation (EC) N° 1882/2003 of the European Parliament and of the Council⁸;
 - *...(indicate respective national law transposing the CPD; only if the national law of the Member State of the issuing approval body so requires);*
 - Common Procedural Rules for Requesting, Preparing and the Granting of European Technical Approvals set out in the Annex to Commission Decision 94/23/EC⁹;
 - **Guideline** *...(indicate title and number of ETA Guideline on the basis of which the ETA is granted, unless ETA is issued without an ETA Guideline in accordance with point 3.2 of the Common Procedural Rules, pursuant to Article 9(2) of the CPD).*
- 2 The *...(name of issuing approval body)* is authorized to check whether the provisions of this European Technical Approval are met. Checking may take place in the manufacturing plant(s). Nevertheless, the responsibility for the conformity of the products to the European Technical Approval and for their fitness for the intended use remains with the holder of the European Technical Approval.

⁶ Official Journal of the European Communities N° L 40, 11.2.1989, p. 12

⁷ Official Journal of the European Communities N° L 220, 30.8.1993, p. 1

⁸ Official Journal of the European Union N° L 284, 31.10.2003, p. 1

⁹ Official Journal of the European Communities N° L 17, 20.1.1994, p. 34

- 3 This European Technical Approval is not to be transferred to manufacturers or agents of manufacturers other than those indicated on page 1, or manufacturing plants other than those /indicated on page 1/ laid down in the context/ of this European Technical Approval *(delete as appropriate)*.
- 4 This European Technical Approval may be withdrawn by *...(name of issuing approval body)* in particular pursuant to information by the Commission according to Article 5(1) of Council Directive 89/106/EEC.
- 5 Reproduction of this European Technical Approval including transmission by electronic means shall be in full. However, partial reproduction can be made with the written consent of *...(name of issuing approval body)*. In this case partial reproduction has to be designated as such. Texts and drawings of advertising brochures shall not contradict or misuse the European Technical Approval.
- 6 The European Technical Approval is issued by the approval body in its official language(s). This (These) version(s) corresponds (correspond) fully to the version circulated in EOTA. Translations into other languages have to be designated as such.

Page 3 and following pages of the ETA

with headline Page ... of ETA-xx/xxxx, issued on dd.mm.yyyy[, validity extended on dd.mm.yyyy]

II SPECIFIC CONDITIONS OF THE EUROPEAN TECHNICAL APPROVAL

1 Definition of products and intended use

1.1 Definition of the construction product (kit)

..... *(Specific text)*

1.2 Intended use

..... *(Specific text)*

The provisions made in this European technical approval are based on an assumed working life of the *...(product)* of ... years[, provided that the conditions laid down in section(s) 4.2 / 5.1 / 5.2 for the packaging / transport / storage / installation / use / maintenance / repair are met]. The indications given on the working life cannot be interpreted as a guarantee given by the producer, but are to be regarded only as a means for choosing the right products in relation to the expected economically reasonable working life of the works.

2 Characteristics of products and methods of verification

..... (Specific text)

Include following note in section "Emission of dangerous substances or radiation":

Note: In addition to the specific clauses relating to dangerous substances contained in this European Technical Approval, there may be other requirements applicable to the products falling within its scope (e.g. transposed European legislation and national laws, regulations and administrative provisions). In order to meet the provisions of the Construction Products Directive, these requirements need also to be complied with, when and where they apply.

3 Evaluation and attestation of conformity and CE marking

3.1 System of attestation of conformity

If a EC decision has been published which lays down the AoC system for the construction product concerned:

According to the decision 2003/728/EC of the European Commission¹⁰ the system 1 of attestation of conformity applies.

This system of attestation of conformity is defined as follows:

System 1: Certification of the conformity of the product by a approved certification body on the basis of:

- (a) Tasks for the manufacturer:
 - (1) factory production control;
 - (2) further testing of samples taken at the factory by the manufacturer in accordance with a prescribed test plan;
- (b) Tasks for the approved body:
 - (3) initial type-testing of the product;
 - (4) initial inspection of factory and of factory production control;
 - (5) continuous surveillance, assessment and approval of factory production control.

Note: Approved bodies are also referred to as "notified bodies".

¹⁰ Official Journal of the European Communities L 262/34 of 14.10.2003

3.2 Responsibilities

3.2.1 Tasks of the manufacturer

3.2.1.1 Factory production control

The manufacturer shall exercise permanent internal control of production. All the elements, requirements and provisions adopted by the manufacturer shall be documented in a systematic manner in the form of written policies and procedures, including records of results performed. This production control system shall insure that the product is in conformity with this European technical approval.

The manufacturer may only use initial / raw / constituent materials (*as relevant*) stated in the technical documentation of this European technical approval.

The factory production control shall be in accordance with the "Control Plan of *...(date)* relating to the European technical approval ETA *...(number)* issued on *...(date)*" which is part of the technical documentation of this European technical approval. The "Control Plan" is laid down in the context of the factory production control system operated by the manufacturer and deposited at the *...(name of the approval body)*.¹¹

The results of factory production control shall be recorded and evaluated in accordance with the provisions of the "Control Plan".

3.2.1.2 Other tasks of manufacturer

..... (*Specific text, if relevant*)

The manufacturer shall, on the basis of a contract, involve a body (bodies) which is (are) approved for the tasks referred to in section 3.1 in the field of *...(product)* in order to undertake the actions laid down in section 3.3. For this purpose, the "control plan" referred to in sections 3.2.1.1 and 3.2.2 shall be handed over by the manufacturer to the approved body or bodies involved.

The manufacturer shall make a declaration of conformity, stating that the construction product is in conformity with the provisions of the European technical approval ETA *...(number)* issued on *...(date)*.

3.2.2 Tasks of approved bodies

¹¹ The "control plan" is a confidential part of the European technical approval and only handed over to the approved body or bodies involved in the procedure of attestation of conformity. See section 3.2.2.

The approved body (bodies) shall perform the

- initial type-testing of the product,
- initial inspection of factory and of factory production control ,
- continuous surveillance, assessment and approval of factory production control ,

in accordance with the provisions laid down in the "Control Plan of *...(date)* relating to the European technical approval ETA -*...(number)* issued on *...(date)*".

The approved body (bodies) shall retain the essential points of its (their) actions referred to above and state the results obtained and conclusions drawn in (a) written report (reports).

The approved certification body involved by the manufacturer shall issue an EC certificate of conformity of the product stating the conformity with the provisions of this European technical approval.

In cases where the provisions of the European technical approval and its "Control Plan" are no longer fulfilled the certification body shall withdraw the certificate of conformity and inform the *...(name of approval body)* without delay.

3.3 CE marking

The CE marking shall be affixed on the *...(product itself - indicate where on the product, if necessary; or the label attached to it; packaging; accompanying commercial document, e.g. the EC declaration of conformity)*. The letters „CE“ shall be followed by the identification number of the approved certification body, where relevant, and be accompanied by the following additional information:

- the name and address of the producer (legal entity responsible for the manufacture),
- the last two digits of the year in which the CE marking was affixed,
- the number of the EC certificate of conformity for the product (*only for AoC systems 1+ and 1*),
- the number of the EC certificate for the factory production control (*only for AoC systems 2+ and 2*),
- the number of the European technical approval,
- the number of the guideline for European technical approval (*only for ETAs issued on the basis of an ETAG*)
- *... (indicate characteristics, performances, use categories, etc. of the product as listed in accordance with the provisions of the ETAG),*

4 Assumptions under which the fitness of the product(s) for the intended use was favourably assessed

4.1 Manufacturing

..... *(Specific text, as far as relevant)*

The European technical approval is issued for the product on the basis of agreed data/information, deposited with the ...*(Approval Body name)*, which identifies the product that has been assessed and judged. Changes to the product or production process, which could result in this deposited data/information being incorrect, should be notified to the ...*(Approval Body name)* before the changes are introduced. The ...*(Approval Body name)* will decide whether or not such changes affect the ETA and consequently the validity of the CE marking on the basis of the ETA and if so whether further assessment or alterations to the ETA, shall be necessary.

4.2 Installation *(if relevant)*

..... *(Specific text, as far as relevant)*

5 Indications to the manufacturer *(if relevant)*

5.1 Packaging, transport and storage *(if relevant)*

..... *(Specific text, as far as relevant)*

5.2 Use, maintenance, repair *(if relevant)*

..... *(Specific text, as far as relevant)*

ANNEX 1 - DESCRIPTION OF PRODUCT(S)

..... *(Specific text and/or drawings, as far as relevant)*

..... *(Give further annexes as far as necessary)*