

European Organisation for Technical Approvals
Europäische Organisation für Technische Zulassungen
Organisation Européenne pour l'Agrément Technique

Established pursuant to Annex II of the Council Directive 89/106 of 21 December 1988 on the approximation of laws, regulations and administrative provisions of Member States relating to construction products (Construction Products Directive)

ETAG N° 026

GUIDELINE FOR EUROPEAN TECHNICAL APPROVAL

of

Fire Stopping and Fire Sealing Products

Part 2 Penetration Seals

Progress file

August 2011

This Guideline for European Technical Approval is established and published in accordance with Article 11 of the Construction Products Directive as a basis for the preparation and issue of European technical approvals in accordance with Article 9.1 of the Construction Products Directive.

European Technical Approvals are issued by approval bodies authorised and notified in accordance with Article 10 of the Construction Products Directive. These bodies are organized in EOTA.

The European Technical Approval, according to the Construction Products Directive, is a favourable technical assessment of the fitness for use of a construction product and the technical specification of the assessed product, serving as basis for the CE marking of this product when and where a harmonised standard according to the Directive is not or not yet available.

Due to technical innovation and the progress of the state of the art, guidelines for technical approval might not reflect the latest developments and experiences gained in approval procedures. The reader of this Guideline is therefore advised to check with an EOTA member whether there are further provisions which have to be taken into account in the use of the Guideline.

Copy right: EOTA

Note: The copy right refers to the English reference version established by EOTA. For publications in accordance with Article 11.3 of the Construction Products Directive the national laws, regulations and administrative provisions of the Member State concerned are applicable.

Table of contents

Page

1	Scope of the ETAG	4
1.1	Definition of the construction product	4
1.2	Intended use of the construction product	6
1.3	Assumed working life of the construction product	8
1.4	Terminology.....	8
1.4.1	Common terms relating to the Construction Products Directive.....	8
1.4.2	Specific terms used in this part of the ETAG.....	8
1.5	Procedure in the case of a significant deviation from the ETAG.....	9
2	Assessment of fitness for use	10
2.1	Meaning of "fitness for use".....	10
2.2	Elements of the assessment of fitness for use	10
2.3	Relationship of requirements to the product characteristics and methods of verification and assessment	10
2.4	Product characteristics relevant for the fitness for use	11
2.4.1	Reaction to fire.....	11
2.4.2	Resistance to fire	11
2.4.3	Air permeability	13
2.4.4	Water permeability	13
2.4.5	Release of dangerous substances.....	13
2.4.6	Mechanical resistance and stability.....	13
2.4.7	Resistance to impact / movement	14
2.4.8	Adhesion	14
2.4.9	Airborne sound insulation.....	14
2.4.10	Thermal resistance	14
2.4.11	Water vapour permeability	14
2.4.12	Durability and Serviceability	14
3	Evaluation and attestation of conformity and CE marking	18
3.1	System of attestation of conformity	18
3.2	Tasks and responsibilities for the manufacturer and notified bodies	18
3.2.1	Tasks for the manufacturer	18
3.2.2	Tasks for notified bodies	23
3.2.3	Special methods of control and testing used for the evaluation	23
3.3	CE marking and accompanying information.....	24
4	Assumptions under which the fitness for the intended use is assessed	24
4.1	Manufacture of the product.....	24
4.2	Packaging, transport, storage of the product.....	24
4.3	Installation of the product in the works	25
4.3.1	Information accompanying the product	255
4.3.2	Service support construction.....	25
4.3.3	Services conveyed.....	25
4.4	Use, maintenance, repair	25
4.5	Auxiliary components	25
5	Identification of the construction product	25
5.1	Means of identification.....	25
5.2	Product characteristics which are relevant for identification checking	29
6	Format of Etas issued on the basis of the ETAG	29
7	Reference documents	29
7.1	EC Documents	29
7.2	Product Specifications	30
7.3	Test methods and classification standards.....	30
7.4	Others	322
Annex A	Mounting and Fixing Procedures for Reaction to Fire Tests	33
A.1	Tests according to EN 13823 (SBI).....	33
A.2	Tests according to EN ISO 11925-2 (small burner test).....	37
Annex B	Test Procedures	38
B.1	IR (Infra-Red Spectroscopy).....	38
B.2	Thermo-analytical methods	38
B.2.1	Thermo-gravimetric Analysis (TGA)	38
B.2.2	DTA (Differential Thermo Calorimetry).....	38
B.3	Content of non-volatile components	38
B.4	Loss of mass on heating	38
B.5	Mechanical properties	38
B.5.1	Compressive strength	38

	B.5.2	Tensile strength	38
	B.5.3	Hardness of sealants (cured)	38
	B.5.4	Tear strength.....	38
	B.5.5	Flexibility	39
B.6	Density		399
	B.6.1	Sealants, coatings and other paste like materials	399
	B.6.2	Foams (in-situ, cured condition)	39
	B.6.3	Mineral wool	399
	B.6.4	Non-compacted bulk density (mortar, filling material for pillows)	39
	B.6.5	Pre-foamed products (e.g. blocks, plugs).....	39
	B.6.6	Boards other than Calcium silicate, Mineral wool and Gypsum based boards.....	399
B.7	Viscosity		399
	B.7.1	Liquids with high viscosity	39
	B.7.2	Liquids with low viscosity	39
	B.7.3	Uncured sealants	399
B.8	"Melting point" of mineral wool		39
	B.8.1	Visual method	40
	B.8.2	Thermo-analytical methods.....	40
	B.8.3	Chemical Analysis (for FPC)	41
	B.8.4	Determination of the melting point of mineral fibre insulating materials.....	41
B.9	Curing behaviour		41
B.10	Dimensions.....		41
	B.10.1	Thickness	411
	B.10.2	Other dimensions	411
	B.10.3	Particle size distribution	411
B.11	Dimensional stability.....		42
	B.11.1	Foams	42
	B.11.2	Mortar	43
B.12	Visual examination		44
Annex C Water permeability test method			45
Addendum: Format of ETA issued on the basis of the ETAG.....			46

Foreword

This ETA-Guideline has been drawn up by the EOTA Task Group "Penetration Seals" of the WG 11.01/04 "Fire Stopping and Fire Sealing Products".

This ETA-Guideline - Part 2 "Penetration seals" shall be used in conjunction with the ETA-Guideline "Fire Stopping and Fire Sealing Products" - Part 1 "General". The same numbering of paragraphs as in Part 1 - "General" is used. If a paragraph is not mentioned, then the text in Part 1 - "General" applies without modification.

If the product is a reactive product or a kit containing a reactive product, the ETA-Guideline – Part 2 "Penetration Seals" shall also be used in conjunction with the ETA-Technical Report N° 024.

1 SCOPE OF THE ETAG

1.1 Definition of the construction product

A penetration seal is either formed from a single product, from a kit or from a combination with other products assembled on site.

Table 1-1 Examples of products intended to be used as penetration seals:

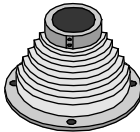
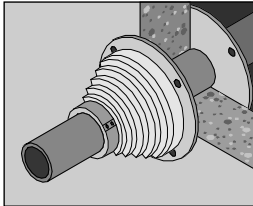
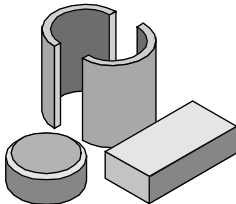
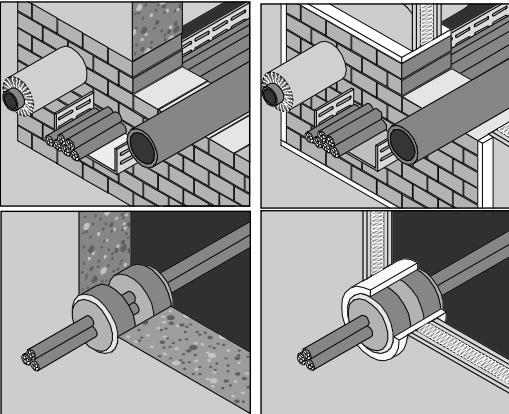
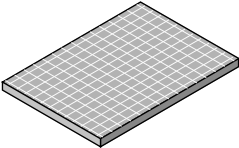
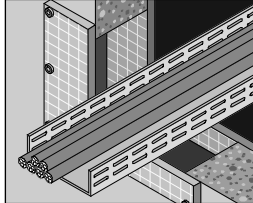
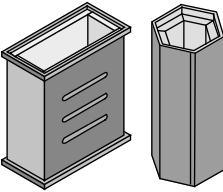
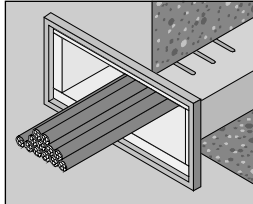
Designation	Illustration ¹ of the	
	product/component	penetration seal
Bellows seals		
Blocks, plugs		
Boards		
Cable boxes		

¹ The illustrations only show an example in terms of size of the seal, type and number of services, distances etc.

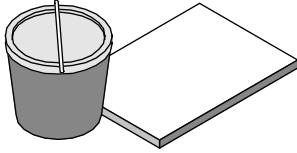
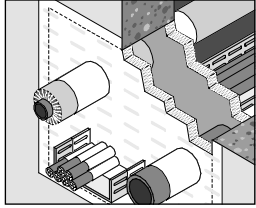
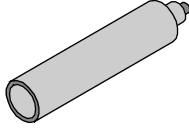
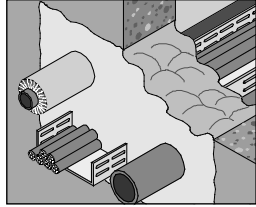
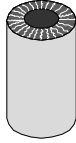
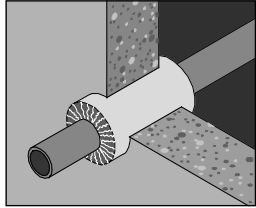
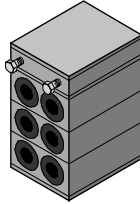
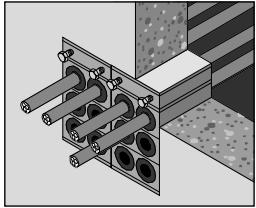
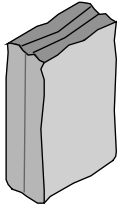
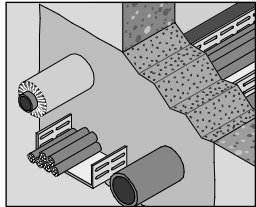
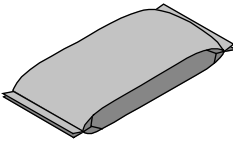
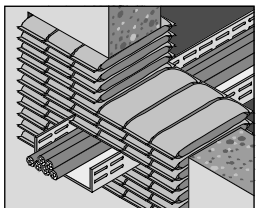
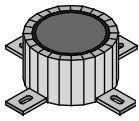
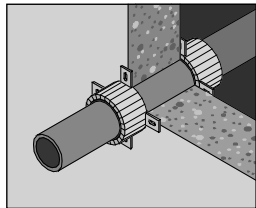
<p>Coated mineral wool slabs (e.g. intumescent or ablative coating)</p>		
<p>Foams</p>		
<p>Mineral wool</p>		
<p>Modular systems</p>		
<p>Mortar</p>		
<p>Pillows (also referred to as “bags” or “cushions”)</p>		
<p>Pipe closure devices</p>		
<ul style="list-style-type: none"> • Collars (integrated into or outside the wall / floor) 		

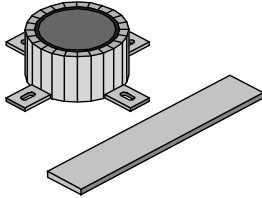
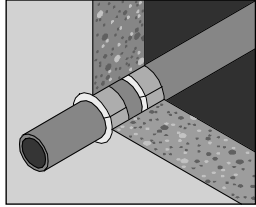
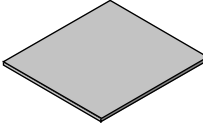
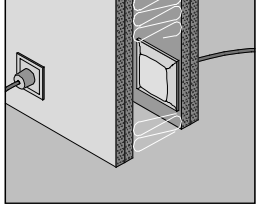
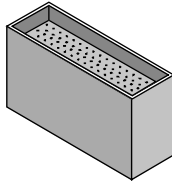
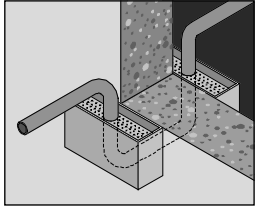
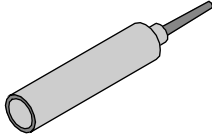
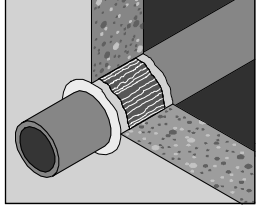
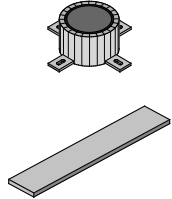
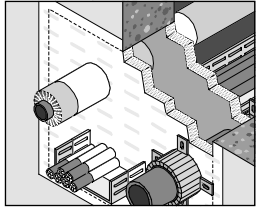
<ul style="list-style-type: none"> • Wraps (integrated into a wall or floor) including strips and composite strips 		
<ul style="list-style-type: none"> • Mechanically actuated systems for pipes 	variable	variable
Putties		
Sand gaskets		
Sealants/Mastics		
Combinations of the products named above		

A penetration seal may contain either one type of the services listed in chapter 1.2, (1)-(7), or different types. The number of services is variable.

1.2 Intended use of the construction product

This ETAG shall be used to deliver European Technical Approvals for products² for which the manufacturer declares the performance as a penetration seal which is used to maintain the fire resistance of a separating element at the position where services pass through.

This ETAG covers products to be used as penetration seals intended to be penetrated by the following services (exhaustive list)³:

- (1) cables (single or bundled), cable carriers, e.g. cable trays, ladders, baskets
- (2) bus bars, bus bar trunking units

² In this ETAG the term „product“ is used for a single product or for a kit

³ Penetration seals used to seal gaps around chimneys, air ventilation systems, fire rated ventilation ducts, fire rated service ducts, shafts, smoke extraction ducts, dampers and smoke control dampers are excluded from this ETAG.

- (3) pipes⁴ and conduits of reaction to fire class A1 according to EN 13501-1⁵ with a melting or decomposition point greater than 1000°C (e.g. steel, cast iron, copper and copper alloys, nickel alloys), either insulated or non-insulated, hereafter referred to as "metal pipes". Included in this group are the above pipes with a coating provided the overall reaction to fire class is minimum A2.
- (4) trunking of reaction to fire class A1 according to EN 13501-1 with a melting or decomposition point greater than 1000°C. Included in this group are the above trunkings with a coating provided the overall reaction to fire class is minimum A2.
- (5) pipes⁴, trunking and conduits of reaction to fire class A1 or A2 according to EN 13501-1 with a melting or decomposition point equal to or less than 1000°C (e.g. lead, aluminium and aluminium alloys) and/or the risk of fracture (glass, fibre cement), either insulated or non-insulated.
- (6) pipes⁴ not classified A1 or A2 according to EN 13501-1 (e.g. made from thermoplastic or thermosetting material) including non-homogeneous materials (e.g. glass fibre reinforced plastic pipes or layered pipes), either insulated or non-insulated, hereafter referred to as "plastic pipes".
- (7) trunking and conduits not classified A1 or A2 according to EN 13501-1 (e.g. made from thermoplastic material or thermosetting material) including non-homogeneous materials, either insulated or non-insulated, hereafter referred to as "plastic trunkings" and "plastic conduits".

A penetration seal may contain either a single type of the services described above, or various types (mixed penetrations). The number of services may vary (including blank penetration seals where no services are included). The services may or may not include service support constructions.

Penetration seals may be used in various environmental conditions, described by the following use categories, related to the type of environmental conditions. These are based on the general principles specified in Part 1 – "General". The use categories are:

Type X: intended for use in conditions exposed to weathering.

Type Y₁: intended for use at temperatures below 0°C with exposure to UV but no exposure to rain

Type Y₂: intended for use at temperatures below 0°C, but with no exposure to rain no UV.

Type Z₁: intended for use in internal conditions with humidity equal to or higher than 85 % RH excluding temperatures below 0°C⁶, without exposure to rain or UV

Type Z₂: intended for uses in internal conditions with humidity lower than 85 % RH excluding temperatures below 0°C, without exposure to rain or UV.

Requirements relevant for the establishment of the use categories are presented in 2.4.12.

Note 1: Products that meet requirements for type X, meet the requirements for all other types. Products that meet requirements for type Y₁ also meet the requirements for type Y₂, Z₁ and Z₂. Products that meet the requirements for type Y₂ also meet the requirements for type Z₁ and Z₂. Products that meet the requirements for type Z₁, also meet the requirements for type Z₂.

Note, however, that although it is acceptable for a penetration seal to be intended for indoor applications only, the construction process may result in it being subjected to more exposed conditions for a period before the building envelope is closed. In this case there are two possibilities:

1. Special provisions need to be made to protect temporarily the exposed penetration seals according to the instructions of the manufacturer which are referenced in the ETA.
2. The penetration seal shall be evaluated as if it was to be used for exposed applications (type X).

The product's resistance to environmental conditions other than those listed above is not covered by reference to specific test methods in this part of the ETAG (see 2.4.12.1.1) and may be assessed on a case by case basis as necessary. The Approval Body shall obtain suitable evidence for the assessment and present details in the ETA.

⁴ Pipes of or around conveyor systems and trackbound transportation systems are excluded.

⁵ In this text "classified according to EN 13501-1" means classification according to EN 13501-1, or classification A1 according to Decision 96/603/EEC as amended or according to a relevant CWFT Decision as stated in the FOREWORD of EN 13501-1

⁶ These uses apply for internal humidity class 5 in accordance with EN ISO 13788.

1.3 Assumed working life of the construction product

The provisions and the verification and assessment methods included or referred to in this ETAG have been written based upon the assumed working life of the Fire Stopping and/or Fire Sealing Product for the intended use of 25 years when installed in the works, provided that the Fire Stopping and/or Fire Sealing Product is subject to appropriate use and maintenance (see 4.4). However, if the product is a reactive material or includes a reactive material, the working life is assumed to be 10 or 25 years depending on available evidence. These provisions are based upon the current state of the art and the available knowledge and experience.

Additional assumptions made are given in Part 1 – "General".

"Assumed working life" means that, when an assessment following the ETAG provisions is made, and when this working life has elapsed, the real working life may be, in normal use conditions, considerably longer without major degradation affecting the Essential Requirements.⁷

The indications given as to the working life of the construction product cannot be interpreted as a guarantee given by the product manufacturer or his representative or the Approval Body issuing the ETA, but are regarded only as a means for choosing the appropriate products in relation to the expected economically reasonable working life of the works (see 5.2.2 of Interpretative Documents).

1.4 Terminology

1.4.1 Common terms relating to the Construction Products Directive

For the meaning of these terms see EOTA document "Common terms used in Guidelines for European technical approval" published on the EOTA website.

1.4.2 Specific terms used in this part of the ETAG

1.4.2.1 Blank penetration seal:

A seal without penetrating services that seals an aperture in a separating element

1.4.2.2 Bellows Seal:

A flexible seal, often based on a coated fabric sleeve, to allow movement of services

1.4.2.3 Block:

Product, available in a variety of shapes and sizes; generally cuboid for rectangular penetrations
See also *Plugs*.

1.4.2.4 Bus Bar/Bus Bar trunking unit:

Bus bar: A low impedance conductor to which several electric circuits can be connected.
For bus bar trunking unit see EN 60439-2

1.4.2.5 Cable box:

A metal frame, with intumescent inlays, that forms a type of channel, often incorporating plastic lids (to prevent the passage of cold smoke)

1.4.2.6 Cable bundle:

Several cables running in the same direction and bound closely together by mechanical means

1.4.2.7 Collar:

See *Pipe closure device*

1.4.2.8 Conduit:

A metal or plastic casing designed to accommodate cables. Normally a conduit is circular or oval in section.
See also *Trunking*

1.4.2.9 Foam:

Material, that cures at room temperature, increasing its volume upon application and creating a cellular structure

⁷ The real working life of a product incorporated in a specific works depends on the environmental conditions to which that works is subject and the particular conditions of the design, execution, use and maintenance of that works may be outside this ETAG. Therefore it cannot be excluded that in these cases the real working life of the product may also be shorter than the assumed working life.

1.4.2.10 Intumescent sleeve:

Pipe penetration seal, in the form of a longitudinally split cylinder, generally made from a base material containing intumescent material

1.4.2.11 Mixed penetration seal:

A seal, that allows the installation of different types of services listed in chapter 1.2, (1)-(7) in a single opening.

1.4.2.12 Modular system:

System comprising a steel frame into which elastomeric blocks are installed, compressed around the service.

1.4.2.13 Mortar:

A blend of gypsum or cement based powder, fillers, water and chemical modifiers, with or without reinforcement.

1.4.2.14 Pillow (also referred to as “bag” or “cushion”):

Malleable, pillow-like bag, filled with reactive or non-reactive material, for the temporary or permanent closing of penetrations or openings.

1.4.2.15 Pipe closure device:

A pre-fabricated, heat activated device that, under fire exposure, acts to crush plastic pipes or service ducts that pass through vertical or horizontal separating elements and/or fill the hollow space with an intumescent foam. Two types are considered here: collars and wraps.

Collars incorporate an outer casing which acts as a restraint for an intumescent material, enabling the collar to be either surface fixed to the separating element or incorporated within it.

Wraps have no casing and hence shall be located within the separating element, which acts as a restraint for the intumescent.

1.4.2.16 Pipe diameter:

Where “pipe diameter” is used in this ETAG this refers to the nominal external diameter of the service pipe.

1.4.2.17 Plug:

As blocks, but cylindrical/conical in shape (for circular penetrations)

1.4.2.18 Putty:

Material similar to some sealants/mastics capable of being formed and directly installed by hand, but remaining in a plastic condition

1.4.2.19 Sand Gasket:

An open metal frame, which is fixed in a wall and filled with specific sand; the cables/services run through the sand.

1.4.2.20 Sealant/Mastic:

Single or multi-component material, comprising organic and/or inorganic fillers pre-dispersed in a binder (i.e. acrylic, polysulphide, silicone etc.), that cures or dries after application to an elastic or plasto-elastic material.

1.4.2.21 Service support construction:

A mechanical support provided in the form of clips, ties, hangers, ladder racks or trays, or any device designed to carry the load of the penetrating services.

1.4.2.22 Small cable penetration seal:

See EN 1366-3:2009

1.4.2.23 Trunking:

A metal or plastic casing designed to accommodate cables. Normally trunking is square or rectangular in section.

See also *Conduit*.

1.4.2.24 Wrap:

See *pipe closure device*

1.5 Procedure in the case of a significant deviation from the ETAG

See Part 1 – “General”

2 ASSESSMENT OF FITNESS FOR USE

2.1 Meaning of "fitness for use"

See Part 1 – "General"

2.2 Elements of the assessment of fitness for use

See Part 1 – "General"

2.3 Relationship of requirements to the product characteristics and methods of verification and assessment

The product characteristics, methods of verification and assessment criteria which are relevant for the fitness of Fire Stopping and Fire Sealing Products for the intended use referred to in 1.2 are given in Table 1 of Part 1 – "General" and apply except where modified or specified below.

Table 1 - Product characteristics and methods of verification and assessment

Nr	Product characteristic	Option "No Performance Determined"	Method of verification and assessment	Expression of product performance
Essential Requirement 1: Mechanical resistance and stability				
	None			
Essential Requirement 2: Safety in case of fire				
1	Reaction to fire	Permitted: class F according to EN 13501-1	2.4.1	Classes A1-F according to EN 13501-1 ⁵
2	Resistance to fire 4.2.3 Limitation of generation and spread of fire and smoke within construction works	Not permitted	2.4.2	Classification according to EN 13501-2
Essential Requirement 3: Hygiene, health and environment				
3	Air permeability (material property)	Permitted	2.4.3	Declared value
4	Water permeability (material property)	Permitted	2.4.4	Pass / fail
5	Release of dangerous substances	Permitted	2.4.5	Indication of dangerous substances or "No dangerous substances" ⁸
Essential Requirement 4: Safety in use				
6	Mechanical resistance and stability	Permitted	2.4.6	See N° 7 of this table
7	Resistance to impact/movement	Permitted	2.4.7	Impact energy value
8	Adhesion *)	Permitted	2.4.8	See N° 7 of this table
Essential Requirement 5: Protection against noise				
9	Airborne sound insulation	Permitted	2.4.9	Single number rating

⁸ EU data base see: <http://ec.europa.eu/enterprise/construction/cpd-ds/index.cfm>

Essential Requirement 6: Energy economy and heat retention				
10	Thermal properties	Permitted	2.4.10	Declared value
11	Water vapour permeability **)	Permitted	2.4.11	Declared value
General aspects relating to fitness for use ***)				
12	Durability and serviceability	Not permitted	2.4.12	Use category regarding environmental conditions
*) This characteristic is placed under ER 4 for convenience, but also relates to other ER as well, particularly ER 2 **) This characteristic also relates to ER 3 ***) Aspects of durability and economy of the works (see CPD Annex 1, sentence 1 and 2) which are not dealt with under Essential Requirements 1 to 6. Such aspects are also referred to as "serviceability".				

2.4 Product characteristics relevant for the fitness for use

2.4.1 Reaction to fire

2.4.1.1 Method of verification

Case 1: Normal case

See Part 1 – "General" for general information.

If the test regime for a certain class requires a test according to EN 13823 (SBI) the mounting and fixing procedure described in Annex A.1 shall be used. Due to the nature of the SBI test it shall not be used for products such as collars and plugs. For these products EN ISO11925-2 shall be applied to determine compliance with the requirements for Class E, if required.

Further details for tests according to EN ISO 11925-2 are given in Annex A.2.

Case 2: Products satisfying the requirements for the fire reaction class A1, without the need for testing

See Part 1 – "General"

Case 3: Products classified without the need for further testing (CWFT)

See Part 1 – "General"

2.4.1.2 Method of assessing and judging

The product shall be classified according to EN 13501-1.

2.4.2 Resistance to fire

2.4.2.1 Method of verification

An assembly representative of the assembled system in which the Fire Stopping and/or Fire Sealing Product is intended to be incorporated, installed or applied shall be tested, using the test method relevant for the corresponding fire resistance class, in order to be classified according to EN 13501-2.

The test configuration shall be determined based on the desired field of application, taking account of the standard configurations and the rules given in EN 1366-3:2009 and this ETAG.

In addition to the provisions given above, the largest envisaged size of all penetration seals shall be tested without services (blank penetration seal). A blank penetration seal test may be omitted for mortar seals, seals made from rigid boards and mineral wool boards of a density of minimum 140 kg/m³ and for penetration seals which by their nature cannot be used without services. The exception for rigid boards and mineral wool boards is not permitted in case the seal includes a splice, i.e. is made from more than one single board, or its size exceeds 1,5 m².

The performance of a blank penetration seal may differ from one where services are included as these may support the seal during the test, particularly if shrinkage occurs due to decomposition. The worst result of the tests with and without services shall be used for classification.

2.4.2.2 Method of assessing and judging

The penetration seal shall be classified according to EN 13501-2 in relation to its intended use, taking into account the rules given in EN 1366-3:2009.

The intention of a test of a blank penetration seal is to provide information on the maximum permissible seal size. The result of a blank penetration seal shall not be used for a stand alone classification but always be accompanied by test results / classification of the penetration seal including services

If the penetration seal has different classifications depending e.g. on the installed services or the installation conditions, each classification shall be listed in the ETA together with its associated conditions. This classification shall refer to the maximum fire resistance duration which was demonstrated in the fire test (although the test also meets the requirements of lower classifications).

Classification of mixed penetration seals:

Mixed penetration seals shall be classified according to EN 13501-2 including the identification of the end configuration of the pipes, e.g. EI 30-U/U, for cases where pipes are included in the field of application.

The following rules shall be applied in relation to the assessment of integrity or insulation:

Test results achieved on a single cable may be used for classification of the seal with this single cable type, provided the cable is clearly defined by its designation according to the related standard. Classification relating to the insulation/sheath materials or the diameter of the cable is not permitted.

For tests using option 1 of EN 1366-3:2009, annex F.4.2 the following rule shall be applied:

In the case that option 1 is used and the results for the cables in the standard mixed module are worse than in the standard cable module, the results for the standard mixed module shall be used for classification of the mixed penetration seal related to the cables. The results for the standard cable configuration may be used for the classification of a cable seal. If the pipe result is lower than the cable result, than the pipe result shall be used for the classification of the mixed penetration seal.

In the case that option 1 is used and the results for the cables in the cable module are worse than in the mixed module, the results for the cable module shall be used for classification of the mixed penetration seal related to the cables. If the pipe result is lower than the cable result, then the pipe result shall be used for the classification of the mixed penetration seal.

The lowest performance determined with thermocouples 3, 4, 5, 6 and 8 according to Figure 3 of EN 1366-3:2009 shall be used for the classification of the seal.

The lowest performance determined with thermocouples 1 and 2 according to Figure 3 of EN 1366-3:2009 for any single service incorporated in a penetration seal shall constitute the performance of that seal unless the field of application is restricted according to the field of application rules.

If the performance determined for a cable carrier is lower than the performance determined for the cables on top of it (and both results are above the lowest classification permitted by EN 13501-2), the seal may be classified for installation in openings with cables and for installation in openings with cable carriers (with or without cables) separately, using the lowest relevant test result.

When using EN 1366-3:2009, section A.3, the following shall be observed:

In case the performance of cable group "Small" is lower than the performance of cable groups "Medium" and/or "Large" the performance of cable group "Small" shall be used for the classification of the seal (also, when only cables of cable groups "Medium" and "Large" are installed). In case the performance of cable group "Medium" is lower than the performance of cable group "Large" the performance of cable group "Medium" shall be used for the classification of the seal (also, when only cables of cable group "Large" are installed).

Additional rules:

Section E.2.7.4 of EN 1366-3:2009 shall not be used, as far as no sufficient test evidence is available.

Field of application rules for pipe end configuration of metal pipes

		Tested			
		U/U	C/U	U/C	C/C
Covered	U/U	Y	N	N	N
	C/U	Y	Y	Y	N
	U/C	Y	N	Y	N
	C/C	Y	Y	Y	Y
Y = acceptable, N = not acceptable					

2.4.3 Air permeability

2.4.3.1 Method of verification

The principles of the test method described in EN 1026 shall be applied. The window test sample described in the standard shall be replaced with a suitably designed sample of the penetration seal without services.

It is impractical to give a standard method for determining air permeability of the penetration seals, including services, due to the wide variation of service configurations.

2.4.3.2 Method of assessing and judging

The test result for the air permeability of the material shall be presented as area specific leakage rate with the unit being $\text{m}^3\text{h}^{-1}\text{m}^{-2}$.

Note 2: This is a deviation from EN 1026.

2.4.4 Water permeability

2.4.4.1 Method of verification

If a test for water permeability of the seal material itself is required, the test method described in Annex C shall be used.

It is impractical to give a standard method for determining water permeability of the penetration seals, including services, due to the wide variation of service configurations.

2.4.4.2 Method of assessing and judging

The water permeability of the product shall be given in qualitative terms; e.g. "water permeable" or "not water permeable".

2.4.5 Release of dangerous substances

2.4.5.1 Method of verification

See Part 1 – "General"

2.4.5.2 Method of assessing and judging

See Part 1 – "General"

2.4.6 Mechanical resistance and stability

2.4.6.1 Method of verification

See 2.4.7.1

Note 3: It is assumed that the impact test covers both static and dynamic loads.

2.4.6.2 Method of assessing and judging

See 2.4.7.2

2.4.7 Resistance to impact / movement

2.4.7.1 Method of verification

For products that can be used to form a blank seal and where no precautions (precautions/protection are not covered by this ETAG) are taken to prevent a person stepping onto a horizontal penetration seal or falling against a vertical, or sloped, penetration seal, tests according to EOTA TR 001 shall be used to show evidence of impact resistance taking account of the following:

- The tests shall be performed without services passing through.
- The size of the test specimen for impact resistance shall be that covered by the fire resistance classification but limited to a maximum⁹ of 1 m x 1,5 m.
- Only one specimen may be used for both safety in use and serviceability.
- Where the size of the penetration seal is in excess of 150 mm x 150 mm but less than or equal to 150 mm x 400 mm the test method described in EOTA TR001, clause 3 applies. Where the size is in excess of 150 mm x 400 mm clause 2 of that document also applies.

2.4.7.2 Method of assessing and judging

The zone type for which the product is suitable, by reference to EOTA TR 001, shall be given in the ETA together with the maximum dimensions of the penetration seal and the type of impactor used.

⁹ The limitation is valid only for seals of a maximum seal size of less than 2 m x 3 m in wall applications or 2 m x infinite m in floor applications.

2.4.8 Adhesion

2.4.8.1 Method of verification

Adhesion is covered by verifications and/or tests performed according to 2.4.7.

2.4.8.2 Method of assessing and judging

See 2.4.7.2

2.4.9 Airborne sound insulation

2.4.9.1 Method of verification

If a test is required to determine $R_w(C; C_{tr})$ values it shall be conducted according to EN ISO 10140 (part 1, 2, 4 and 5).

Taking into account the large types and ranges of services considered, the test shall be carried out without services passing through the specimen, using the "specific small sized opening" (clause 3.3.3 of EN ISO 10140-5)

Note 4: It is not the intention of this test to assess insufficiencies at the interface of the seal with services.

2.4.9.2 Method of assessing and judging

The measured airborne sound insulation shall be expressed as a single number rating $R_w(C; C_{tr})$ in accordance with EN ISO 717-1.

2.4.10 Thermal resistance

2.4.10.1 Method of verification

See Part 1 – "General"

2.4.10.2 Method of assessing and judging

See Part 1 – "General"

2.4.11 Water vapour permeability

2.4.11.1 Method of verification

See Part 1 – "General"

Note 5: Water vapour permeability is considered as a material property. Thus tests are carried out without services passing through the specimen. It is not the intention of this test to show water vapour leakage at the interface of the seal with services.

2.4.11.2 Method of assessing and judging

See Part 1 – "General"

2.4.12 Durability and Serviceability

2.4.12.1 Method of verification

2.4.12.1.1 General

There are two groups of materials used for penetration seal products:

- Materials covered by a standard: see 2.4.12.1.2 and 2.4.12.1.4.
- Materials not covered by a standard: see 2.4.12.1.3 and 2.4.12.1.4.

The assessment of any single product may require considering materials of both types.

Where the penetration seal is intended to be used in environmental conditions not covered by X, Y₁, Y₂, Z₁ and Z₂, e.g. acid, alkaline or saline conditions, further confirmatory evidence or tests will be necessary as determined by the Approval Body.

2.4.12.1.2 Durability of materials covered by a standard (e.g. metal or plastic components)

2.4.12.1.2.1 Painted/coated steel

The adequacy of a coating on steel shall be assessed in accordance with EN ISO 12944 in its various parts.

2.4.12.1.2.2 Galvanised steel

The adequacy of zinc corrosion protection shall be assessed in accordance with EN ISO 14713, which gives general recommendations on corrosion protection.

2.4.12.1.2.3 Coil-coated steel

Coil-coated steel shall be assessed in accordance with EN 10169.

2.4.12.1.2.4 *Coil-coated aluminium*

Coil-coated aluminium shall be assessed in accordance with EN 1396.

2.4.12.1.2.5 *Stainless steel*

Stainless steels shall be classified by reference to EN 10088. Annex B of EN 10088-1:2005 contains general guidance on the use of stainless steels including the aspect of corrosion resistance.

Ferritic stainless steels have relatively low corrosion resistance and their use is normally restricted to mild indoor or similarly protected environments. This type of stainless steel is suitable for use in use categories Z₁, Z₂ and Y.

Note 6: Austenitic stainless steel: The most common alloys are 1.4301 (X5CrNi18-10) and 1.4401 (X5CrNiMo17-12-2). These austenitic stainless steels are normally suitable for use in all use categories as defined in 1.2. However, where high chloride contents or more severe conditions are likely to be present in the environment (e.g. rooms with indoor swimming pools, facades in cities with heavy traffic, in coastal areas), alloys with higher molybdenum content, e.g. 1.4429 (X2CrNiMoN17-13-3), 1.4539 (X1NiCrMoCu25-20-5) or 1.4529 (X1NiCrMoCuN25-20-7), may be necessary.

Austenitic-ferritic steels, e.g. 1.4462 (X2CrNiMoN22-5-3), are comparable to a CrNiMo-steel with 2,5 to 3% Mo.

2.4.12.1.2.6 *Thermoplastic polymeric materials*¹⁰

Thermoplastic polymeric materials used in these products are generally used to form cover plates, frames etc. and thus do not fulfil a primary function. It is therefore sufficient to ensure that the component/material possesses characteristics that define it as being an acceptable quality moulding or extrusion.

Extruded profiles in PVC-U shall be designated and assessed for suitability using EN 13245-1 or 3 and the associated tests in EN 13245-2. These standards allow a distinction to be made between profiles that are intended to be externally exposed and those that are for internal use only.

In determining suitability of a profile in a particular application the Approval Body shall take due account of the consequences of failure, in particular related to the costs of access and the associated dismantling of the building.

For injection moulded components, the effects of heating shall be determined, using the method described in EN ISO 580, on 3 samples selected from each of 5 production batches.

After conditioning, no weld line shall have opened completely and no cracks or de-lamination shall penetrate more than 50 % of the thickness, at the point of injection. If 1 of any 3 specimens exhibits a failure a retest may be undertaken on 6 further specimens. If any of these samples fails the product shall be deemed unacceptable.

2.4.12.1.2.7 *Mineral wool*

Mineral wool complying with those requirements of EN 13162 or EN 14303 which are related to durability is deemed to satisfy the durability requirements for use categories Z₁, Z₂, Y₁ and Y₂ (as tested to one of these standards).

2.4.12.1.3 **Materials not covered by a standard**

2.4.12.1.3.1 *General*

The principle of the durability tests is to select suitable physico-chemical or technological properties of the product and to check whether these properties have changed during exposure of the product to defined exposure conditions.

2.4.12.1.3.2 *The properties to assess shall be:*

- Board type products covered by ETAG 018 Part 4: see the relevant chapter of that ETAG.
- Board type products other than covered by ETAG 018 Part 4 (i.e. boards specifically designed for the application in penetration seals):

A case by case approach shall be taken to define the relevant properties depending on the nature of the product. Examples of properties that may be selected are appearance (e.g. blistering, cracking), density, thickness and mechanical properties.

¹⁰ This assessment is not intended to assess the durability and tightness of wrappings/casings used to protect reactive materials that are not durable on their own. These are assessed as part of the reactive component.

- **Blocks, plugs:**

<i>Property</i>	<i>Test method</i>
Appearance	B.12
Density	B.6.5
Expansion ratio ¹¹	See EOTA TR 024: July 2009 , clause 3.1.11
Expansion pressure ¹¹ (if relevant)	See EOTA TR 024:July 2009, clause 3.1.12

- **Coatings, fillers (non-reactive):**

<i>Property</i>	<i>Test method</i>
Appearance	B.12
Flexibility	B.5.5

- **Coatings, fillers (reactive):**

<i>Property</i>	<i>Test method</i>
Appearance	B.12
Expansion ratio ¹¹	See EOTA TR 024:July 2009, clause 3.1.11
Flexibility	B.5.5
LOI ¹²	See EOTA TR 024: July 2009, clause 3.1.14

- **Collars (inlay), wraps (including intumescent strips and composite strips) and intumescent sleeves:**

<i>Property</i>	<i>Test method</i>
Appearance	B.12
Expansion ratio ¹¹	See EOTA TR 024:2009, clause 3.1.11
Expansion pressure ¹¹ (if relevant)	See EOTA TR 024:2009, clause 3.1.12

- **Fabrics:**

<i>Property</i>	<i>Test method</i>
Appearance	B.12
Tear strength of fabric	B.5.4.1

- **In-situ Foams (non-reactive):**

<i>Property</i>	<i>Test method</i>
Appearance	B.12
Density of cured foam	B.6.2 (trimmed surfaces)

- **In-situ Foams (reactive):**

<i>Property</i>	<i>Test method</i>
Appearance	B.12
Density of cured foam	B.6.2 (trimmed surfaces)
Expansion ratio ¹¹	See EOTA TR 024: July 2009, clause 3.1.11
Expansion pressure ¹¹ (if relevant)	See EOTA TR 024: July 2009, clause 3.1.12

¹¹ only relevant for intumescent products

¹² only for ablative coatings

- **Mortar (cement based) and Plaster (gypsum based):**

<i>Property</i>	<i>Test method</i>
Appearance	B.12
Compression strength after 3, 7 or 28 days	B.5.1.1
Compressive strength fully dried (gypsum based)	B.5.1.2

- **Pillows**

<i>Property</i>	<i>Test method</i>
Bag	
Appearance	B.12
Tear strength of fabric	B.5.4.1
Tear strength of seams	One method from B.5.4.2 shall be used
Filling material (non-reactive):	
A case by case approach to define the properties shall be taken	
Filling material (reactive):	
Expansion ratio ¹¹	See EOTA TR 024: July 2009, clause 3.1.11
Expansion pressure ¹¹ (if relevant)	See EOTA TR 024: July 2009, clause 3.1.12
LOI ¹³	See EOTA TR 024: July 2009, clause 3.1.14

- **Putties, Sealants:**

<i>Property</i>	<i>Test method</i>
Appearance	B.12
Hardness after curing	one of the methods of B.5.3 shall be used

- **Rubber components of modular systems:**

<i>Property</i>	<i>Test method</i>
Appearance	B.12
Tensile strength	one of the methods of B.5.2.1 shall be used

2.4.12.1.3.3 Exposure conditions

- Use category related to environmental conditions type Z₂:
See EOTA TR 024: July 2009 (reactive materials) clause 4.2.7
- Use category related to environmental conditions type Z₁:
See EOTA TR 024: July 2009 (reactive materials) clause 4.2.6
- Use category related to environmental conditions type Y₂:
See EOTA TR 024: July 2009 (reactive materials) clause 4.2.5
- Use category related to environmental conditions type Y₁:
See EOTA TR 024: July 2009 (reactive materials) clause 4.2.4
- Use category related to environmental conditions type X:
See EOTA TR 024: July 2009 (reactive materials) clause 4.2.3

2.4.12.1.4 Component and materials compatibility

The Approval Body shall examine the design of the product and make an assessment, using well-established principles, of the suitability of materials in contact. It is impossible to prescribe all the possible risk areas but these include the possibility of bi-metallic corrosion, the effects of over-painting etc.

¹³ Only for ablative products

2.4.12.2 Method of assessing and judging

2.4.12.2.1 Materials/products covered by a standard

When the material/product (e.g. metal parts or other components) meet the relevant requirements given in the standards referenced they are considered as being durable.

2.4.12.2.2 Materials/products not covered by a standard

Basically, to achieve a positive assessment of durability no change in the assessed property is allowed. However, as repeatability and reproducibility of most of the test methods to determine relevant properties are unknown a deviation of the mean values of the property assessed before and after exposure of not more than 15% may be taken as a positive result of the durability assessment.

In case of high scatter of the test results an alternative is to take a statistical approach, using an appropriate high number of test specimens. This approach may be used to demonstrate that the mean value of the property after exposure does not deviate from the mean value before exposure.

3 EVALUATION AND ATTESTATION OF CONFORMITY AND CE MARKING

3.1 System of attestation of conformity

See Part 1 – "General"

3.2 Tasks and responsibilities for the manufacturer and notified bodies

3.2.1 Tasks for the manufacturer

The corner stones of the actions to be undertaken by the manufacturer of the Fire Stopping and/or Fire Sealing Product in the procedure of attestation of conformity are laid down in Part 1 –"General" and in Table 3.

The alternatives for implementation are:

- The ETA holder produces the product, i.e. he ensures FPC himself
- The product/component is supplied to the ETA holder, i.e. the ETA holder needs to ensure the supplier performs the FPC as specified in the ETA or accompanying documentation.

Table 3 - Control plan for the manufacturer; corner stones

Nr	Subject/type of control (product, raw/constituent material, component - indicating characteristic concerned)	Test or control method	Criteria, if any	Minimum number of specimens ¹⁴	Minimum frequency of control ¹⁵
Factory production control (FPC)					

Table 3.1 Blocks, plugs

1	TGA or DTA ¹⁶	EOTA TR 024	-	see ¹⁴	1/10 b
2	Content of non-volatile components ¹⁶	B.3	-	see ¹⁴	1/10 b
3	Loss of mass on heating ¹⁶	B.4	-	see ¹⁴	1/10 b
4	Dimensions	B.10	-	see ¹⁴	1/b

¹⁴ One specimen is normally considered to be sufficient. The final number of specimens is to be defined in the ETA or accompanying documents.

¹⁵ The abbreviations given stand for the frequency of tests: 1/b = once per batch, 1/10b = once per 10 batches, 1/6m = once per 6 month, 1/h = once per hour, decl = declaration of conformity of the supplier of the component(s)

batch:

for continuous production the frequency shall be defined by the Approval Body on a case by case basis depending on the peculiarities of the manufacturing process and the level of quality management system installed;

for discontinuous production: A batch is the specific amount of material produced at one time using the same process and the same conditions of manufacture.

¹⁶ Method 1 or methods 2 plus 3 may be chosen alternatively but the frequency may be further reduced if the components / raw materials and their related mass is recorded automatically (e.g. by means of an automatically recording balance) and an appropriate quality management system is installed.

5	Density	B.6.5	-	see ¹⁴	1/b
6	Expansion ratio ¹¹	EOTA TR 024: July 2009, clause 3.1.11	-	see ¹⁴	1/b
7	Expansion pressure ¹¹	EOTA TR 024: July 2009, clause 3.1.12	-	see ¹⁴	1/b

Table 3.2 Boards

Table 3.2.1 Calcium silicate boards

1	See ETAG No 018 Part 4				
---	------------------------	--	--	--	--

Table 3.2.2 Mineral wool boards

Mineral wool boards manufactured according to EN 14303 or EN 13162 ¹⁷

1	see EN 14303 or EN 13162				
2	Apparent density	B 6.3	-	see ¹⁴	1/h or decl
3	"Melting point"	one of the methods of B.8 shall be used	-	see ¹⁴	1/b of raw material or decl

Table 3.2.3 Gypsum boards

1	See EN 520 for characteristics relevant for this ETAG				
2	Apparent density	EN 520	-	see ¹⁴	1/h or decl

Table 3.2.4 Boards other than Calcium silicate, Mineral wool and Gypsum based boards

1	TGA or DTA ¹⁶	B.2	-	see ¹⁴	1/10 b
2	Content of non-volatile components ¹⁶	B.3	-	see ¹⁴	1/10 b
3	Loss off mass on heating ¹⁶	B.4	-	see ¹⁴	1/10 b
4	Dimensions	B.10	-	see ¹⁴	1/b
5	Apparent density	B.6.6	-	see ¹⁴	1/b

Table 3.3 Modular systems

Modules					
1	TGA or DTA ¹⁶	B.2	-	see ¹⁴	1/10 b
2	Content of non-volatile components ¹⁶	B.3	-	see ¹⁴	1/10 b
3	Loss of mass on heating ¹⁶	B.4	-	see ¹⁴	1/10 b
4	Dimensions	B.10	-	see ¹⁴	1/b
5	Density	B.6.5	-	see ¹⁴	1/b
6	Shrinkage cavities / Homogeneity	(minimum mass for given dimension)	-	see ¹⁴	1/b

¹⁷ Products produced according to EN 14303 or EN 13162 may be suitable for penetration seal applications but "melting point" and density are properties relevant for this application which are not covered in these standards.

Frame					
6	Dimensions	B.10	-	see ¹⁴	1/b
7	Steel specification to EN standard	-	-	see ¹⁴	1/b (decl)
8	Thickness of protective coating (if relevant)		-	see ¹⁴	1/b (decl)

Table 3.4 Cable boxes

Intumescent inlays					
1	TGA or DTA ¹⁶	B.2	-	see ¹⁴	1/10 b
2	Content of non-volatile components ¹⁶	B.3	-	see ¹⁴	1/10 b
3	Loss of mass on heating ¹⁶	B.4	-	see ¹⁴	1/10 b
4	Dimensions	B.10	-	see ¹⁴	1/b
5	Expansion ratio	EOTA TR 024: July 2009, clause 3.1.11	-	see ¹⁴	1/b
6	Expansion pressure (if relevant)	EOTA TR 024: July 2009, clause 3.1.12	-	see ¹⁴	1/b
Housing					
7	Dimensions	B.10	-	see ¹⁴	1/b
8	Steel specification to EN standard	-	-	see ¹⁴	1/b (decl)
9	Thickness of protective coating (if relevant)		-	see ¹⁴	1/b (decl)

Table 3.5 Coatings/fillers ¹⁸ (for coated mineral wool slabs)

Coating / filler					
1	TGA or DTA ¹⁶	B.2	-	see ¹⁴	1/10 b
2	Content of non-volatile components ¹⁶	B.3	-	see ¹⁴	1/10 b
3	Loss of mass on heating ¹⁶	B.4	-	see ¹⁴	1/10 b
4	Viscosity of "liquid" material	B.7	-	see ¹⁴	1/b
5	Density of "liquid" material	B.6.1	-	see ¹⁴	1/b
6	Expansion ratio ⁷	EOTA TR 024: July 2009, clause 3.1.11	-	see ¹⁴	1/b
7	LOI ¹⁹	EOTA TR 024: July 2009, clause 3.1.14	-	see ¹⁴	1/b

¹⁸ In the context of coated mineral wool slab seals a filler is the material used around the perimeter of the seal, between the mineral wool slabs and between the mineral wool slab and the penetrating services for adhesion or filling gaps. It may be the same product as the coating but with a higher viscosity.

¹⁹ Only for ablative products; For FPC of ablative components a combination of flexibility, ash content/content of non-volatile components and density is considered to be sufficient but if an enterprise owns the equipment and skilled staff for LOI-testing the method may be used for FPC.

8	Flexibility ²⁰	EOTA TR 024: July 2009, clause 3.1.13	-	see ¹⁴	1/b
Pre-coated mineral wool slab					
9	Thickness of the coating	B.10	-	see ¹⁴	1/b

Table 3.6 Collars

Inlay					
1	TGA or DTA ¹⁶	B.2	-	see ¹⁴	1/10 b
2	Content of non-volatile components ¹⁶	B.3	-	see ¹⁴	1/10 b
3	Loss of mass on heating ¹⁶	B.4	-	see ¹⁴	1/10 b
4	Dimensions	B.10	-	see ¹⁴	1/b
5	Expansion ratio ⁷	EOTA TR 024: July 2009, clause 3.1.11	-	see ¹⁴	1/b
6	Expansion pressure ⁷ (if relevant)	EOTA TR 024: July 2009, clause 3.1.12	-	see ¹⁴	1/b
Housing					
7	Thickness of steel sheet	B.10	-	see ¹⁴	1/b (decl)
8	Thickness of Zn layer (if relevant)		-	see ¹⁴	1/b (decl)
9	Thickness of protective coating (if relevant)		-	see ¹⁴	1/b (decl)
10	Tensile strength of steel		-	see ¹⁴	1/b (decl)
11	Dimensions	B.10	-	see ¹⁴	1/b

Table 3.7 Pillows

Filling material					
1	TGA or DTA ¹⁶	B.2	-	see ¹⁴	1/10 b
2	Content of non-volatile components ¹⁶	B.3	-	see ¹⁴	1/10 b
3	Loss of mass on heating ¹⁶	B.4	-	see ¹⁴	1/10 b
4	Quantity (mass) per bag		-	see ¹⁴	1/b
5	Bulk density	B.6.4	-	see ¹⁴	1/b
6	Particle size distribution	B.10.3	-	see ¹⁴	1/b
7	Expansion ratio ¹¹	EOTA TR 024: July 2009, clause 3.1.11	-	see ¹⁴	1/b
Bag					
8	Type of bag material(s)		-	see ¹⁴	1/b (decl)
9	Dimensions of empty bag	B.10	-	see ¹⁴	1/b

²⁰ Only for coatings

10	Tear strength of bag (fabric/seams)	B.5.4	-	see ¹⁴	1/10 b ²¹
11	Tear strength of fabric	B.5.4.1	-	see ¹⁴	1/b (decl)
12	Mass per area of fabric		-	see ¹⁴	1/b (decl)
13	Mass per length of thread		-	see ¹⁴	1/b (decl)

Table 3.8 Bellows seals (fabric)

1	Type of material(s)		-	see ¹⁴	1/b (decl)
2	Dimensions	B.10	-	see ¹⁴	1/b
3	Tear strength of fabric	B.5.4.1	-	see ¹⁴	1/b (decl)
4	Mass per area of fabric		-	see ¹⁴	1/b (decl)
5	Tear strength of seams (if relevant)	<i>one of the methods of B.5.4.2 shall be used</i>	-	see ¹⁴	1/10 b
6	Impregnation / flame retardants (quantity per unit area of fabric)		-	see ¹⁴	1/b

Table 3.9 Foams in-situ applied

1	TGA or DTA ¹⁶	B.2	-	see ¹⁴	1/10 b
2	Content of non-volatile components ¹⁶	B.3	-	see ¹⁴	1/10 b
3	Loss of mass on heating ¹⁶	B.4	-	see ¹⁴	1/10 b
4	Density of cured foam	B.6.2	-	see ¹⁴	1/b
5	Expansion ratio ¹¹	EOTA TR 024: July 2009, clause 3.1.11	-	see ¹⁴	1/b
6	Curing behaviour (tack free time)	B.9	-	see ¹⁴	1/b
7	Dimensional stability (change in volume)	B.11	-	see ¹⁴	1/10 b ²²

Table 3.10 Mortar (cement based) and Plaster (gypsum based)

1	TGA or DTA ¹⁶	B.2	-	see ¹⁴	1/10 b
2	Content of non-volatile components ¹⁶	B.3	-	see ¹⁴	1/10 b
3	Loss of mass on heating ¹⁶	B.4	-	see ¹⁴	1/10 b
4	Non-compacted bulk density	B.6.4	-	see ¹⁴	1/b
5	Setting time (if relevant)		-	see ¹⁴	1/b
6	Compressive strength after 3 or 7 days (cement based)	B.5.1.1	-	see ¹⁴	1/b
7	Compressive strength after 28 days (cement based)	B.5.1.1	-	see ¹⁴	1/6 m
8	Compressive strength after 24 hours - fully saturated (gypsum based)	B.5.1.2	-	see ¹⁴	1/b

²¹ If the bag is purchased as a component a declaration of conformity shall be provided for every delivery

²² Depending on how close the result of the approval test is to the threshold value of the specification

9	Compressive strength fully dried (gypsum based)	B.5.1.2	-	see ¹⁴	1/6 m
---	---	---------	---	-------------------	-------

Table 3.11 Sealants/mastics and putties

1	TGA or DTA ¹⁶	B.2	-	see ¹⁴	1/10 b
2	Content of non-volatile components ¹⁶	B.3	-	see ¹⁴	1/10 b
3	Loss of mass on heating ¹⁶	B.4	-	see ¹⁴	1/10 b
4	Density of uncured ("liquid") material	B.6.1	-	see ¹⁴	1/b
5	Viscosity of uncured ("liquid") material	B.7	-	see ¹⁴	1/b
6	Hardness after curing (if relevant)	one of the methods of B.5.3 shall be used	-	see ¹⁴	1/10 b
7	Expansion ratio ¹¹	EOTA TR 024: July 2009, clause 3.1.11	-	see ¹⁴	1/b

Table 3.12 Wraps (including intumescent strips and composite strips), intumescent sleeves

1	TGA or DTA ¹⁶	B.2	-	see ¹⁴	1/10 b
2	Content of non-volatile components ¹⁶	B.3	-	see ¹⁴	1/10 b
3	Loss of mass on heating ¹⁶	B.4	-	see ¹⁴	1/10 b
4	Dimensions	B.10	-	see ¹⁴	1/b
5	Expansion ratio ¹¹	EOTA TR 024: July 2009, clause 3.1.11	-	see ¹⁴	1/b
6	Expansion pressure ¹¹	EOTA TR 024: July 2009, clause 3.1.12	-	see ¹⁴	1/b

3.2.2 Tasks for notified bodies

The corner stones of the actions to be undertaken by the notified body (bodies) in the procedure of attestation of conformity for Fire Stopping and/or Fire Sealing Products are laid down in Table 4.

3.2.2.1 Initial type-testing of the product (ITT)

Direct tests related to the properties listed in the mandate (fire resistance, mechanical resistance and stability, adhesion, resistance to impact/movement, release of dangerous substances) will already have been done as part of the approval tests and it will not normally be necessary for these to be repeated for ITT. However, depending on the degree to which the samples used for the approval testing were representative of the product produced under the conditions of current production (e.g. when prototypes were used), some confirmatory tests may need to be done out of the list given in Table 4.

3.2.2.2 Initial inspection of factory and factory production control (FPC)

The relevant properties are listed in Table 4.

3.2.2.3 Continuous surveillance, judgment and assessment of factory production control (FPC)

The relevant properties are listed in Table 4. The minimum surveillance frequency is normally twice a year.

Table 4 - Control plan for the notified body (bodies); corner stones

Nr	Subject/type of control	Test or control method	Criteria, if any	Minimum number of specimens	Minimum frequency of control
Initial type-testing of the product (ITT)					
See clauses 2.4.1 to 2.4.12 and Table 5 The approval tests are usually acceptable for ITT					
Initial inspection of factory and factory production control (FPC)					
See Part 1 – “General” and Table 3 of this Part					
Continuous surveillance, judgment and assessment of factory production control (FPC)					
See Part 1 – “General” and Table 3 of this Part					

3.3 CE marking and accompanying information

See Part 1 – “General”

Example of CE marking and accompanying information:

 1234	"CE" marking
Any Company Street 1, City, Country 04 1234-CPD-0321	Identification number of notified certification body Name and address of the producer (legal entity responsible for the manufacturer)
ETA-10/1234 ETAG 026 – Part 2 Penetration Seal "YYY" "see ETA-10/1234 for relevant characteristics"	Two last digits of year of affixing CE marking Number of EC certificate of conformity ETA number ETAG number Name (YYY) Reference to ETA for relevant characteristics

4 ASSUMPTIONS UNDER WHICH THE FITNESS FOR THE INTENDED USE IS ASSESSED

4.1 Manufacture of the product

No specific provisions

4.2 Packaging, transport, storage of the product

For general advice see Part 1 – “General”.

When the product, as delivered, has a limited shelf life, it should be assumed that the manufacturer gives a clear indication of that life and, when appropriate, restrictions on the storage conditions (e.g. temperature, humidity).

4.3 Installation of the product in the works

4.3.1 Information accompanying the product

It is assumed that the manufacturer provides information on:

- the use conditions in terms of environmental conditions (e.g. dry indoor use) as covered by the ETA
- the method of preparation of the supporting construction (wall/floor) before installation of the penetration seal

4.3.2 Service support construction

It is assumed that any service support construction is adequately fixed to the building element on both sides of the penetration.

4.3.3 Services conveyed

The approval does not address any risks associated with leakage of dangerous liquids or gases caused by failure of the pipe(s) in case of fire.

It is assumed that compressed air systems are switched off by other means in the case of fire.

The durability assessment does not take account of the possible effect of substances permeating through the pipe onto the penetration seal.

It is assumed that thermal movement in the pipe work will be accommodated in such a way that it does not impose a load on the penetration seal.

4.4 Use, maintenance, repair

It is assumed that the manufacturer provides information for the installer on the method of repair or replacement in case of damage to the penetration seal and, where relevant, on the method for retrofitting or removing services from the penetration seal.

4.5 Auxiliary components

See Part 1 – "General"

5 IDENTIFICATION OF THE CONSTRUCTION PRODUCT

5.1 Means of identification

All components of the Fire Stopping and Fire Sealing Products shall be clearly identified in accordance with section 5 of Part 1 – "General" of this ETAG. Wherever possible a harmonised European Technical Specification shall be used to identify the component. If the product is a reactive material, the EOTA Technical Report "Reactive Products" has to be taken into account. For products not covered by a harmonised European Technical Specification or the EOTA Technical Report 024 "Reactive Products" see Part 1 – "General" and the following:

When the option "Fingerprinting" is taken, for most products IR (Infra-Red Spectroscopy) plus a TGA (Thermo-gravimetric Analysis) or DTA (Differential Thermal Analysis) will be appropriate. ²³

Alternatively, or in addition, the applicant, or a third party at his request, may disclose the formulation to the Approval Body for identification purposes. ²³

For the purpose of testing of physical characteristics the properties listed in Table 5 shall be determined depending on the type of the product. The test methods given are recommendations only. ²⁴

Drawings will be useful particularly for products that are formed or contain formed components such as collars, modular systems / cable boxes or for products that are characterised by a specific geometrical shape, dimensions etc.

In many cases a combination of the options will be taken to cover all necessary aspects.

²³ Finally there are three options to identify the single components of a product: by "fingerprinting" (combination of TG and IR); by depositing the composition and formulation or by verifying physical characteristics. The latter may include a combination of TG or DTA plus Loss of mass on heating/non-volatile components and density or other parameters.

Table 5 – Physical product characteristics, methods of verification and criteria used for checking the product identity

Table 5.1 Blocks, plugs

Number	Product characteristic	Verification method
1	TGA or DTA	B.2
2	Content of non-volatile components	B.3
3	Loss of mass on heating	B.4
4	Dimensions	B.10
5	Density	B.6.5
6	Expansion ratio (if relevant)	EOTA TR 024: July 2009, clause 3.1.11
7	Expansion pressure (if relevant)	EOTA TR 024: July 2009, clause 3.1.12

Table 5.2 Boards

Table 5.2.1 Calcium silicate boards

Number	Product characteristic	Verification method
1	See ETAG No 018 Part 4	

Table 5.2.2 Mineral wool boards

Number	Product characteristic	Verification method
Mineral wool boards manufactured according to EN 14303 or EN 13162 ¹⁷		
1	See EN 14303 or EN 13162 for characteristics relevant for this ETAG	
2	Apparent density	B.6.3
3	"Melting point"	One method from B.8 shall be selected

Table 5.2.3 Gypsum boards

Number	Product characteristic	Verification method
1	See EN 520 for characteristics relevant for this ETAG	
2	Apparent density	EN 520

Table 5.2.4 Boards other than Calcium silicate, Mineral wool and Gypsum based boards

Number	Product characteristic	Verification method
1	TGA or DTA	B.2
2	Content of non-volatile components	B.3
3	Loss of mass on heating	B.4
4	Dimensions	B.10
5	Apparent density	B.6.6

Table 5.3 Modular systems

Number	Product characteristic	Verification method
1	TGA or DTA	B.2
2	Content of non-volatile components	B.3
3	Loss of mass on heating	B.4
4	Dimensions	B.10
5	Density	B.6.5
6	Shrinkage cavities / Homogeneity	(minimum mass for given dimension)

7	Dimensions/design	B.10 / Drawings
8	Steel specification to EN standard	-

Table 5.4 Cable boxes

Number	Product characteristic	Verification method:
1	TGA or DTA	B.2
2	Content of non-volatile components	B.3
3	Loss of mass on heating	B.4
4	Dimensions	B.10 / Drawings
5	Expansion ratio	EOTA TR 024: July 2009, clause 3.1.11
6	Expansion pressure (if relevant)	EOTA TR 024: July 2009, clause 3.1.12
7	Dimensions/design	B.10 / Drawings
8	Steel specification to EN standard	-

Table 5.5 Coatings/fillers ¹⁸ (for coated mineral wool slabs)

Number	Product characteristic	Verification method
1	TGA or DTA	B.2
2	Content of non-volatile components	B.3
3	Loss of mass on heating	B.4
4	Viscosity of "liquid" material	B.7
5	Density of "liquid" material	B.6.1
6	Expansion ratio	EOTA TR 024: July 2009, clause 3.1.11
7	LOI ¹⁹	EOTA TR 024: July 2009, clause 3.1.14
8	Flexibility ²⁰	EOTA TR 024: July 2009, clause 3.1.13

Table 5.6 Collars

Number	Product characteristic	Verification method
<i>Inlay</i>		
1	TGA or DTA	B.2
2	Content of non-volatile components	B.3
3	Loss of mass on heating	B.4
4	Dimensions	B.10 / Drawings
5	Expansion ratio	EOTA TR 024: July 2009, clause 3.1.11
6	Expansion pressure	EOTA TR 024: July 2009, clause 3.1.12
<i>Housing</i>		
7	Thickness of steel sheet	Specification / Drawings
8	Thickness of Zn layer (if relevant)	Specification / Drawings
9	Thickness of protective coating (if relevant)	Specification / Drawings
10	Tensile strength of steel	Specification of steel
11	Dimensions / design	B.10 / Drawings

Table 5.7 Pillows

Number	Product characteristic	Verification method
--------	------------------------	---------------------

1	TGA or DTA	B.2
2	Content of non-volatile components	B.3
3	Loss of mass on heating	B.4
4	Quantity (mass) per bag	
5	Non-compacted bulk density	B.6.4
6	Particle size distribution	B.10.3
7	Expansion ratio	EOTA TR 024: July 2009, clause 3.1.11
8	Type of bag material(s)	Specification / Drawings
9	Dimensions of empty bag	B.10
10	Tear strength of bag (fabric/seams)	B.5.4
11	Tear strength of fabric	B.5.4.1
12	Mass per area of fabric	

Table 5.8 Bellows seals (fabric)

Number	Product characteristic	Verification method
1	Type of material(s)	Specification / Drawings
2	Dimensions	B.10 / Drawings
3	Tear strength of fabric	B.5.4.1
4	Mass per area of fabric	
5	Tear strength of seams (if relevant)	One method from B.5.4.2 shall be used
6	Impregnation / flame retardants (quantity per unit area of fabric)	

Table 5.9 Foams in-situ applied

Number	Product characteristic	Verification method
1	TGA or DTA	B.2
2	Content of non-volatile components	B.3
3	Loss of mass on heating	B.4
4	Density of cured foam	B.6.2
5	Expansion ratio (if relevant)	EOTA TR 024: July 2009, clause 3.1.11
6	Curing behaviour (tack free time)	B.9
7	Dimensional stability (change in volume)	B.11

Table 5.10 Mortar (cement based) and Plaster (gypsum based)

Number	Product characteristic	Verification method
1	TGA or DTA	B.2
2	Content of non-volatile components	B.3
3	Loss of mass on heating	B.4
4	Non-compacted bulk density	B.6.4
5	Setting time	
6	Compressive strength after 3 or 7 days (cement based)	B.5.1.1

7	Compressive strength after 28 days (cement based)	B.5.1.1
8	Compressive strength after 24 hours (fully saturated)	B.5.1.2
9	Compressive strength fully dried (gypsum based)	B.5.1.2
10	Linear expansion on setting (gypsum based)	B.11.2

Table 5.11 Sealants/mastics and putties

Number	Product characteristic	Verification method
1	TGA or DTA	B.2
2	Content of non-volatile components	B.3
3	Loss of mass on heating	B.4
4	Density of uncured ("liquid") material	B.6.1
5	Viscosity of uncured ("liquid") material	B.7
6	Hardness after curing (if relevant)	One method from B.5.3 shall be used
7	Expansion ratio (if relevant)	EOTA TR 024: July 2009, clause 3.1.11

Table 5.12 Wraps (including intumescent strips and composite strips), intumescent sleeves

Number	Product characteristic	Verification method
1	TGA or DTA	B.2
2	Content of non-volatile components	B.3
3	Loss of mass on heating	B.4
4	Dimensions	B.10
5	Expansion ratio	EOTA TR 024: July 2009, clause 3.1.11
6	Expansion pressure	EOTA TR 024: July 2009, clause 3.1.12

5.2 Product characteristics which are relevant for identification checking

See tables 5.1 to 5.12 and the related verification methods in Annex B referenced in the tables.

6 FORMAT OF ETAS ISSUED ON THE BASIS OF THE ETAG

European technical approvals issued on the basis of this ETAG shall be in accordance with the ETA format given in the Addendum to this ETAG.

7 REFERENCE DOCUMENTS

This ETA-Guideline Part 2 incorporates, by dated or undated reference, provisions from other publications. These normative references are cited at the appropriate places in the text and the publications are listed below. For dated references subsequent amendments to, or revisions of these publications, apply to this ETAG only when incorporated in it by amendment or revision. For undated references the latest dated revision of the publication referred to, applies.

For further updating conditions see Part 1 – "General" - Foreword.

7.1 EC Documents

Commission Decision 96/603/EC

Commission Decision of 4 October 1996 establishing the list of products belonging to Classes A 'No contribution to fire' provided for in Decision 94/611/EC implementing Article 20 of Council Directive 89/106/EEC on construction products

Commission Decision 2000/605/EC	Commission Decision of 26 September 2000 amending Decision 96/603/EC establishing the list of products belonging to Classes A 'No contribution to fire' provided for in Decision 94/611/EC implementing Article 20 of Council Directive 89/106/EEC on construction products
Commission Decision 2003/424/EC	Commission Decision of 6 June 2003 amending Decision 96/603/EC establishing the list of products belonging to Classes A 'No contribution to fire' provided for in Decision 94/611/EC implementing Article 20 of Council Directive 89/106/EEC on construction products

7.2 Product Specifications

ETAG 026	Fire Stopping and Fire Sealing Products - Part 1 – "General"
ETAG 018; Part 4	Fire Protective Board, Slab and Mat Products and Kits
EN 1396	Aluminium and aluminium alloys - Coil coated sheet and strip for general applications – Specifications
EN 10088	Stainless steels; Part 1: List of stainless steels Part 2: Technical delivery conditions for sheet/plate and strip of corrosion resisting steels for general and construction purposes Part 3: Technical delivery conditions for semi-finished products, bars, rods, wire, sections and bright products of corrosion resisting steels for general and construction purposes
EN 10169	Continuously organic coated (coil coated) steel flat products; Part 1: General information (definitions, materials, tolerances, test methods) Part 2: Products for building exterior applications Part 3: Products for building interior applications
EN 13162	Thermal insulation products for buildings – Factory made mineral wool (MW) products - Specification
EN 13245	Plastics; Unplasticised poly(vinyl) chloride (PVC-U) profiles for building applications Part 1: Designation of light coloured profiles Part 2: Profiles for internal and external wall and ceiling finishes Part 3: Designation of coloured profiles
EN 14303	Thermal insulation products for building equipment and industrial installations; Factory made mineral wool products (MW). Specification
EN ISO 12944	Paints and varnishes; Corrosion protection of steel structures by protective paint systems Part 1: General introduction Part 2: Classification of environments Part 3: Design considerations Part 4: Types and surface preparation Part 5: Protective paint systems Part 6: Laboratory performance test methods Part 7: Execution and supervision of paint work Part 8: Development of specifications for new work and maintenance
EN ISO 14713	Protection against corrosion of iron and steel in structures; Zinc and aluminium coatings; Guidelines
EN 60439-2	Low-voltage switchgear and controlgear assemblies; Part 2: Particular requirements for busbar trunking systems (busways)

7.3 Test methods and classification standards

EN 520	Gypsum plasterboards, Definition, requirements and test methods
EN ISO 580	Plastics piping and ducting systems; Injection-moulded thermoplastics fittings; Methods for visually assessing effects of heating
EN 1015	Methods of test for mortar for masonry

	Part 1: Determination of flexural and compressive strength of hardened mortar
	Part 11: Determination of flexural and compressive strength of hardened mortar
EN 1026	Windows and doors; Air permeability; Test method
EN 1366-3:2009	Fire resistance tests for service installations; Part 3: Penetration seals
EN 1426	Bitumen and bituminous binders - Determination of needle penetration
EN ISO 1519	Paints and varnishes; Bend test (cylindrical mandrel)
EN 1602	Thermal insulating products for building applications; Determination of the apparent density
EN 12092	Adhesives; Determination of viscosity
EN 13238	Reaction to fire tests for building products: Conditioning procedures and general rules for selection of substrates
EN 13501	Fire classification of construction products and building elements Part 1: Classification using test data from reaction to fire tests Part 2: Classification using test data from fire resistance tests
EN 13823:2002	Reaction to fire tests for building products; Building products excluding floorings exposed to the thermal attack by a single burning item
EN ISO 10140	Acoustics; Laboratory measurement of sound insulation of building elements Part 1: Application rules for specific products Part 2: Measurement of airborne sound insulation Part 4: Measurement procedures and requirements Part 5: Requirements for test facilities and equipment
EN ISO 527-2	Plastics; Determination of tensile properties; Part 2: Test conditions for moulding and extrusion plastics
EN ISO 717-1	Acoustics; Rating of sound insulation of buildings and of building elements; Part 1: Airborne sound insulation
EN ISO 2811	Paints and varnishes; Determination of density Part 1: Pycnometer method Part 2: Immersed body (plummet) method
EN ISO 3219	Plastics; Polymers/resins in the liquid state or as emulsions or dispersions; Determination of viscosity using a rotational viscometer with defined shear rate
EN ISO 3251	Paints, varnishes and plastics; Determination of non-volatile-matter content
EN ISO 3451	Plastics; Determination of ash; Part 1: General methods
EN ISO 11925-2	Reaction to fire tests; Ignitability of building products subjected to direct impingement of flame; Part 2: Single-flame source test
EN ISO 13788	Hygrothermal performance of building components and building elements; Internal surface temperature to avoid critical surface humidity and interstitial condensation; Calculation methods
EN ISO 13934-1	Tensile properties of fabrics; Part 1: Determination of maximum force and elongation at maximum force using the strip method
EN ISO 13935	Seam tensile properties of fabrics and made-up textile articles Part 1: Determination of maximum force to seam rupture using the strip method Part 2: Determination of maximum force to seam rupture using the grab method
ISO 37	Rubber, vulcanised or thermoplastic; Determination of tensile properties
ISO 3049	Gypsum plasters; Determination of physical properties of powder
ISO 7619	Rubber, vulcanized or thermoplastic; Determination of indentation hardness Part 1: Durometer method (Shore hardness) Part 2: IRHD pocket meter method

7.4 Other references

- EOTA TR 001 Determination of impact resistance of panels and panel assemblies
- EOTA TR 024: July 2009 Characterisation, Aspects of Durability and Factory Production Control for Reactive Materials, Components and Products

ANNEX A

Mounting and Fixing Procedures for Reaction to Fire Tests

A.1 Tests according to EN 13823 (SBI)

The product shall be tested in an installation representative of practical use and comprising all components, e.g. sealant, backing material and fixings but without services. The thickness of each component of the penetration seal shall be representative of the installation in practice for the penetration seal size of the intended field of application. The maximum thickness of 200 mm given in EN 13823 may be reduced, provided a minimum unaffected thickness of 10 mm of the product or component forming the surface is left after the test ²⁴.

Regarding the size of the specimen the standard configuration shown in Figure A.1 is normally used ²⁵. Where no lateral spread of flame is expected, outside the area on the long wing covered by the specimen, the configuration shown in Figure A.2 may be used alternatively. When in a test using the configuration according to A.2, lateral spread of flame outside this area is observed the test shall be repeated using the standard configuration according to A.1.

The long wing of specimens that are built from a high number of relatively small parts (e.g. blocks) can be mechanically stabilized by fixing them at the back, to a cross-type frame made of steel (see Figure A.3).

²⁴ This may be relevant for e.g. blocks, pillows or foams. An indicative test, for example using a Bunsen burner will give an estimate of the necessary thickness.

²⁵ The size of the test specimen was chosen considering the fact that even if the size of a single opening is restricted in the ETA because of other reasons, e.g. the resistance to fire performance, it will always be possible to install several penetration seals in a single wall or floor in close proximity. Results of indicative tests with commonly used product types have shown that the full height of the test specimen shall be used to get a reliable result.

Dimensions in millimetres

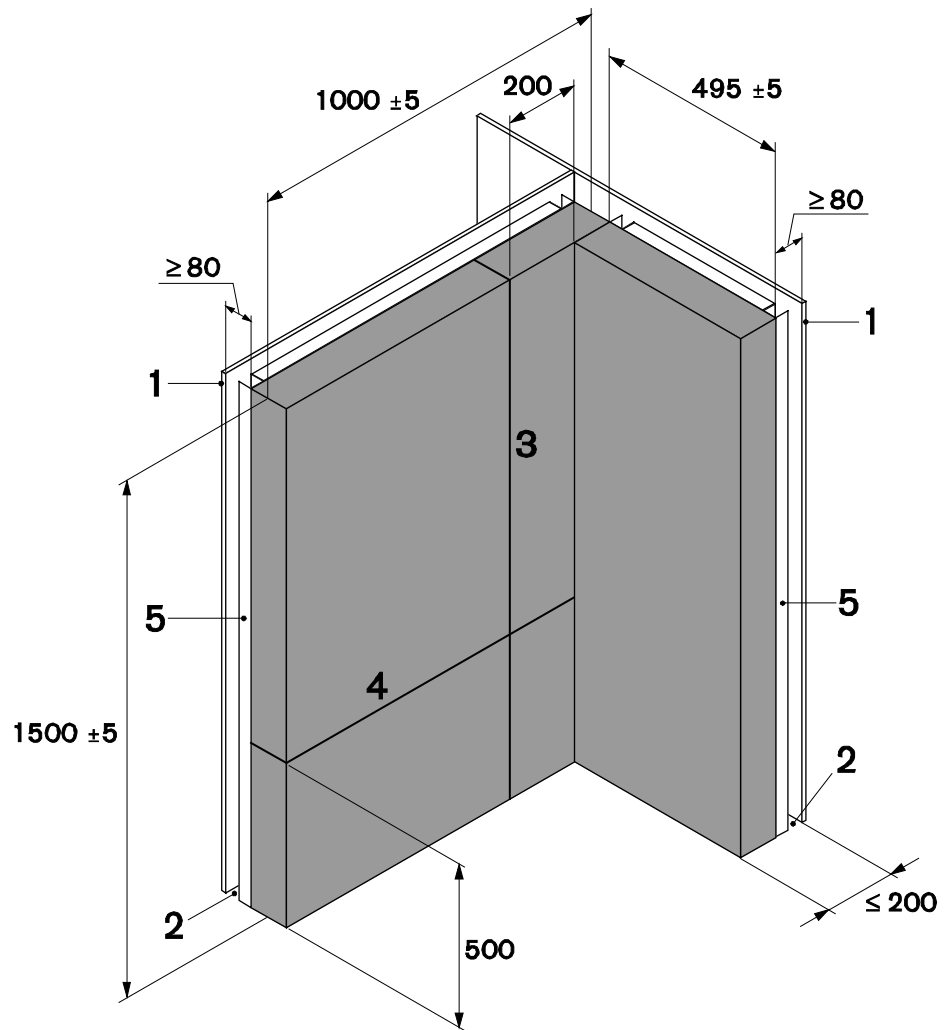

Key

- 1 Backing boards according to EN 13823
- 2 Air gap
- 3 Vertical joint (where relevant)
- 4 Horizontal joint (where relevant)
- 5 Supporting frame (optional, see Figure A.3)

Figure A.1 Standard configuration

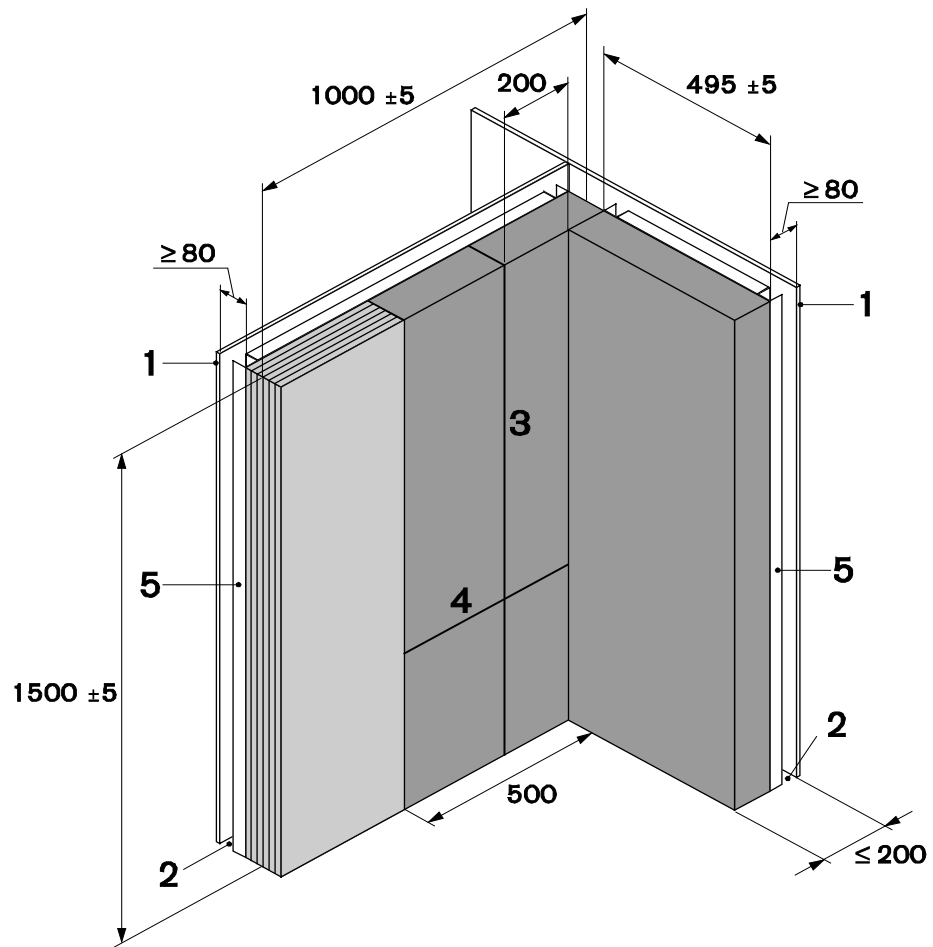

Key



Specimen



Calcium silicate board

- 1 Backing boards according to EN 13823
- 2 Air gap
- 3 Vertical joint (where relevant)
- 4 Horizontal joint (where relevant)
- 5 Supporting frame (optional, see Figure A.3)

Figure A.2 – Configuration when no lateral spread of flame outside the specimen area on the left wing is expected.

When using the configuration according to Figure A.2 the part of the wing that is not covered by the test material shall be made of calcium silicate board.

A

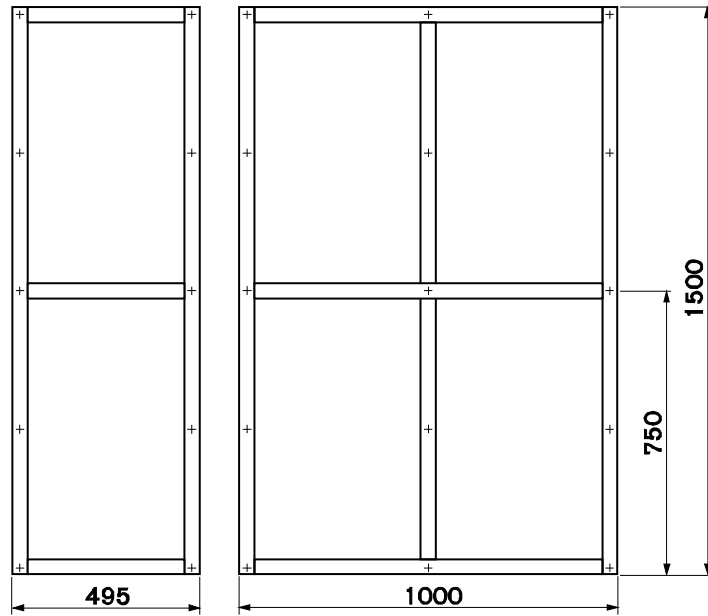

B

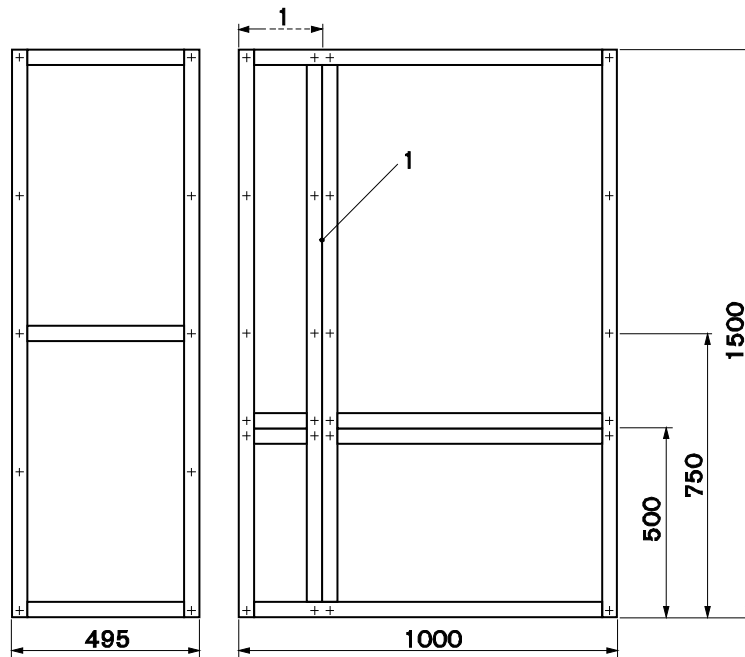

Key

A Frame for specimens without joints

B Frame for specimens with joints

1 Position of the vertical joint ^a

^a The position of the vertical joint and the related frame depends on the thickness of the specimen as the overall length of the long wing is defined with (1000 ± 5) mm and the position of the joint at 200 mm from the corner line when the wings are mounted ready for testing

Figure A.3 Cross-type frame on the back of the long wing

A.2 Tests according to EN ISO 11925-2 (small burner test)

The standard size of the specimen (250 mm x 90 mm x maximum 60 mm) shall be used whenever possible, e.g. by flattening the product or cutting it into the required size.

Where the specimen has a cut surface this surface shall not be used as the test surface exposed to the flame.

Where the geometry or nature of the product does not allow the use of the standard specimen size the following rules apply:

- Where the width of the product is smaller than 90 mm, the actual width of the product is used.
- For coatings used on mineral wool (slabs) the standard mineral wool substrate according to EN 13238 shall be used. The thickness of the coating shall be the maximum of any range requested by the ETA applicant.
- Where the spacing requirements for the test set up do not allow the use of a particular size of a cushion the size shall be used that optimally fits both the spacing and size requirements.
- Modular systems: the rubber modules can be tested in the uncompressed state. At the request of the applicant the compressed state as in practice can also be tested. Ideally a 250 mm x 90 mm x 60 mm specimen is produced. Where this is not feasible a frame closest in size to the standard specimen, filled with "blank" modules (without a hole), shall be used.

Note A1: To achieve a realistic result tests under compression are particularly recommended for soft (e.g. foam-type) products when they are used under compression in practice.

- For thin specimens a calcium silicate backing board shall be used.

According to EN ISO 11925-2 edge flaming is required only where the edge is exposed in practice (protrusion from the surface). This is normally not the case for penetration seals. However for the following products edge flaming will be necessary:

- Pillows
- Collars and wraps.

For wraps which are installed within the opening and whose edge is flush with the surface of the building element, flaming of the small surface that is exposed in practice is used.

For collars: the surface that is exposed in practice shall be exposed.

ANNEX B

Test Procedures

B.1 IR (Infra-Red Spectroscopy)

IR shall be carried out according to the instruction manual of the equipment used. See also EOTA TR 024, Annex C for details when used as identification method (Fingerprint).

B.2 Thermo-analytical methods

B.2.1 Thermo-gravimetric Analysis (TGA)

See EOTA TR 024

B.2.2 Differential Thermo Calorimetry (DTA)

See EOTA TR 024

B.3 Content of non-volatile components

Test according to EN ISO 3251.

The value reported as a declared value for identification shall be the mean value of at least three specimens.

B.4 Loss of mass on heating

Test according to EN ISO 3451-1, subject to the following provisions: As "Loss of mass on heating" is a characteristic of a material, protective foils or coatings shall be removed if at all possible. When the product is tested with a protective foil or coating this shall be recorded to ensure consistency with future tests.

Note B1: The standard was written for plastics but other materials can also be tested following the principles of the standard.

The value reported as a declared value for identification shall be the mean value of at least three specimens.

B.5 Mechanical properties

B.5.1 Compressive strength

B.5.1.1 Mortars (cement based)

Test according to EN 1015-11.

The strength at 3, 7 or 28 days may be determined dependent on whether high early strength or normal cement is used.

B.5.1.2 Plaster (gypsum based)

Test according to EN 1015-11

This method may be applied to gypsum based products subject to the product being tested after 24 hours, fully saturated, and after oven drying at 30°C to 35°C to constant mass.

B.5.2 Tensile strength

B.5.2.1 Rubber

Test according to ISO 37 or EN ISO 527-2.

B.5.3 Hardness of sealants (cured)

Test according to ISO 7619 -1 or ISO 7619-2. The ETA shall specify the method used

B.5.4 Tear strength

B.5.4.1 Fabrics

Test according to EN ISO 13934-1

B.5.4.2 Seam

Test according to EN ISO 13935-1 or EN ISO 13935-2. The ETA shall specify the method used

B.5.5 Flexibility

Test according to EN ISO 1519

B.6 Density

B.6.1 Sealants, coatings and other paste like materials

Sealants, coatings and other paste like materials may be tested according to the principles of EN ISO 2811-1 (pycnometer). The mean value of 3 specimens and the standard deviation shall be reported. For FPC also EN ISO 2811-2 is a suitable method.

B.6.2 Foams (in-situ, cured condition)

A cardboard beaker (coated with paraffin wax) is filled with the foam (taking care to avoid any holes and cavities). The foam is cut at the edge of the beaker after curing. The specimen shall be kept at ambient temperature. Density = mass total – mass beaker / volume of beaker (kg/m³). The mean value of 3 specimens and the standard deviation shall be reported.

B.6.3 Mineral wool

Test according to EN 1602

B.6.4 Non-compacted bulk density (mortar, filling material for pillows)

Test according to ISO 3049.

B.6.5 Pre-formed products (e.g. blocks, plugs)

The density is calculated from the mass and the volume of the specimen. The mass of the specimen shall be determined with a balance of an accuracy of 0,1 g. The dimensions shall be determined to the nearest mm either using a ruler when the product has a regular shape, or determining the volume by using a water displacement technique.

B.6.6 Boards other than Calcium silicate, Mineral wool and Gypsum based boards

Depending on the type of product the test method shall be determined case by case.

B.7 Viscosity

B.7.1 Liquids with high viscosity

Test according to EN ISO 3219

B.7.2 Liquids with low viscosity

Test according to EN 12092

B.7.3 Uncured sealants

Test according to EN 1426

B.8 Behaviour of mineral wool at high temperature (for identification and FPC)

B.8.1 Visual method of determining the "Melting point"

A sample of the mineral wool shall be pre-treated at (550 ± 10)°C in a muffle furnace until the organic binder will be eliminated. Cut cube specimens of 10 mm x 10 mm x 10 mm from the pre-treated sample.

The cube specimens are inserted into a tube furnace having an internal diameter of 25 mm pre-heated to a temperature approximately 30 degrees below the expected melting temperature. This is achieved by placing the specimen on a suitable carrier (e.g. a metal or ceramic pin or spatula) which is supported outside the tube furnace. The specimen is moved slowly to the centre of the furnace, where the temperature sensor is located. The specimen is held for 10 minutes in that position. The specimen is then carefully removed from the furnace and examined to see whether it has melted. The furnace temperature is noted.

If the specimen is unchanged, raise the furnace temperature by 10 degrees, wait until the temperature is stabilized and repeat the test with a new specimen.

If the specimen has melted, lower the temperature by 10 degrees and repeat the measurement with a new specimen. The temperature where the wool started melting is called the “melting” point.

The dimensions of the inner diameter of the tube furnace and the specimen may be changed provided the ratio is kept constant.

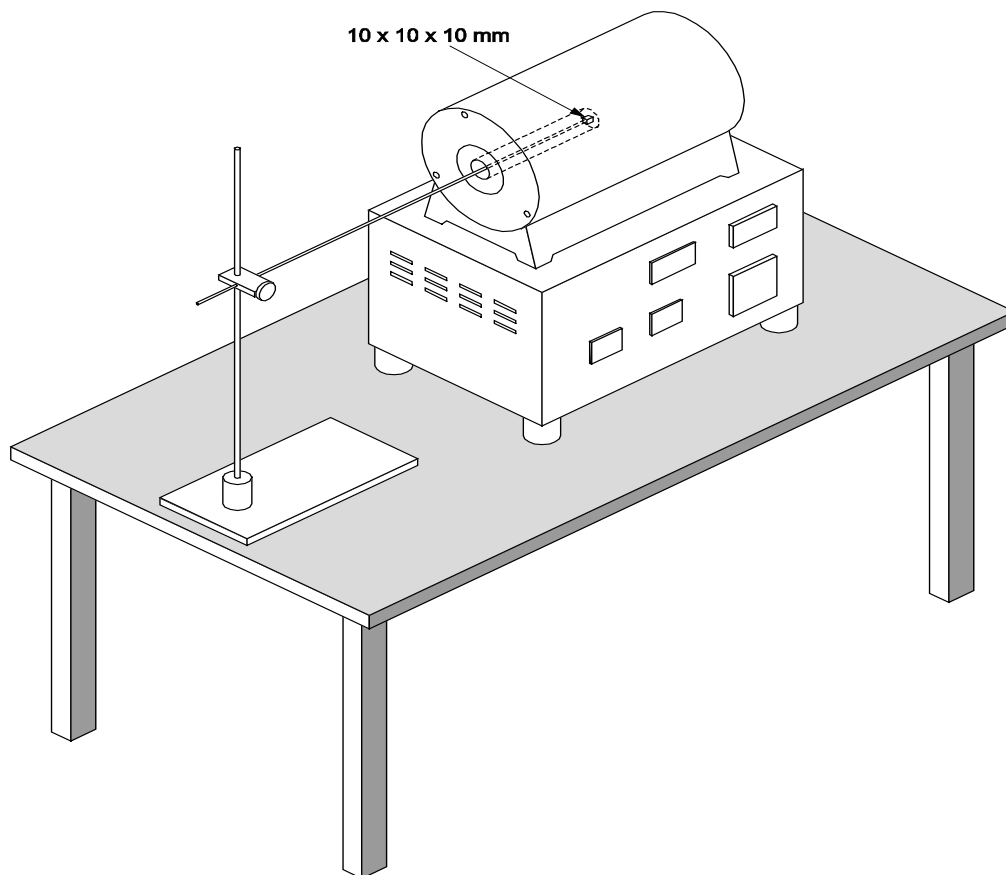

Figure B.1 –Setup for visual method

B.8.2 Thermo-analytical methods

Any thermo-analytical method may be used, e.g. DTA or TGA.

B.8.3 Chemical analysis (for FPC)

The details (definition of the elements/components to be determined) are to be agreed between the Approval Body and the manufacturer and to be outlined in the documentation accompanying the ETA.

B.8.4 Determination of the melting point of mineral fibre insulating materials

This method is suitable for mineral fibre material to test whether its "melting point" is above a temperature of 1000°C.

Preparation

For every mineral fibre material use at least 2 dry samples.

Cut 2 specimens of 500 mm x 500 mm. The maximum thickness shall be 80 mm.

Dry at (23 ± 2) °C and $50 \pm 5\%$ RH until equilibrium (change in mass less than 0,1% within 24 hours).

Apply a steel-plate of a size of 200 mm x 200 mm and a mass of 0,4 kg (causing a pressure of $0,1 \text{ kN/m}^2$) with a hole in the centre for determining the thickness of the material (round up to full millimetre).

The density of every specimen will be determined geometrically from mass and the geometrical dimensions.

Test procedure

Cover both sides of every specimen by a steel-sheet of a thickness of 1 mm and install them vertically into a small scale furnace (e.g. according to DIN 4102-8) and expose the specimen to a heat regime according to the standardized temperature-time curve according to EN 13501-2, clause 4.2, for 90 minutes.

The thickness shall be measured again after exposure (see preparation).

B.9 Curing behaviour

Tack free time of foams: a suitable amount of the material is extruded in to a beaker. Every 2 seconds the surface of the foam is touched by means of a wooden spatula. The tack free time is reached when no foam sticks on the spatula.

B.10 Dimensions

B.10.1 Thickness

The thickness of products in the form of plates, sheets, boards, strips, fabrics, foils etc. is determined by means of a suitable gauge to the nearest 0,1 mm at 5 locations of the specimen. The minimum size of the specimen is 100 mm x100 mm or a minimum length of 500 mm in case of strips.

B.10.2 Other dimensions

The dimensions shall be determined to an accuracy of 0,5% by means of a suitable gauge.

B.10.3 Particle size distribution

The method described for dry material in EN 1015-1 may be used.

B.11 Dimensional stability

B.11.1 Foams

B.11.1.1 General

Dimensional stability is a cured foam's specific parameter of the resistance to shrink or post-expand after curing as measured in this test. The following protocol describes how to measure dimensional stability in a controlled testing environment.

B.11.1.2 Required equipment

- The application tool (e.g. dispenser) that belongs to the tested system
- Spacers (minimum 100 mm x (15 mm ± 1 mm) x 20 mm, made of dimensionally stable material (for example: PE, PTFE,...), on which polyurethane does not adhere.
- AC grade plywood, about 130 mm x 100 mm, so that a net foam area of 100 mm x 100 mm remains. The thickness of the plywood shall be minimum 9,5 mm.
- Hand clamps
- Calipers
- Knife
- Climatic chamber (controlled environment test equipment)
- Heating chamber, dry but unspecified relative humidity

B.11.1.3 Testing

The foam, the application tool, and the substrate shall be conditioned to constant mass in accordance with EN 13238. Three specimens shall be made according to Figure B.1 and B.2. Be sure that the clamps sit directly on the spacers so as not to compress the assembly. The specimen shall have a gap with the required width of approximately 20 mm. The net foam space shall be an area of approximately 100 mm x 100 mm. Figure B.3 shows how the assembly should be oriented during foaming and how the foam should be applied. Again, make sure that the clamps sit directly on the spacers. After 24 hours, remove the hand clamps and the spacers. Cut the excess foam that has expanded from the interior of the assembly so that it is flush with the plywood edges. Measure the initial, inner plywood to plywood board dimensions. After taking the measurements, store the assemblies in the required test climates.

The test climates are:

(40 ± 2) °C / (90 ± 5) % relative humidity

(30 ± 2) °C / (30 ± 5) % relative humidity

B.11.1.4 Evaluation

At day 7 and 14, the specimens shall be removed from the respective test chambers and then stored for a minimum of 2 hours at standard conditions in accordance with EN 13238. At the four corners, the distance between the boards is measured as near as possible to the interior foam surface (distance "c" in Figure B.2). Alternatively, if there are any surface irregularities, the distance can be measured at the exact middle of the specimen where the two spacers were placed (Figures B.3). After the first measurement, place the specimens back in the proper chamber.

B.11.1.5 Dimensional stability calculation

The dimensional stability, d , is calculated as the percentage change in the assembly dimensions:

$$d = \left(\frac{b}{c} \times 100 \right) - 100 (\%)$$

b (mm) = Measured width of the gap after storage in the test chamber

c (mm) = Starting value before storage

The dimensional stability d of one specimen is given by the mean value of the four or two measuring points. The mean value of each assembly and the mean value of all assemblies as well as the standard deviation are recorded.

The overall mean value together with its standard deviation shall be reported.

Dimensions in mm

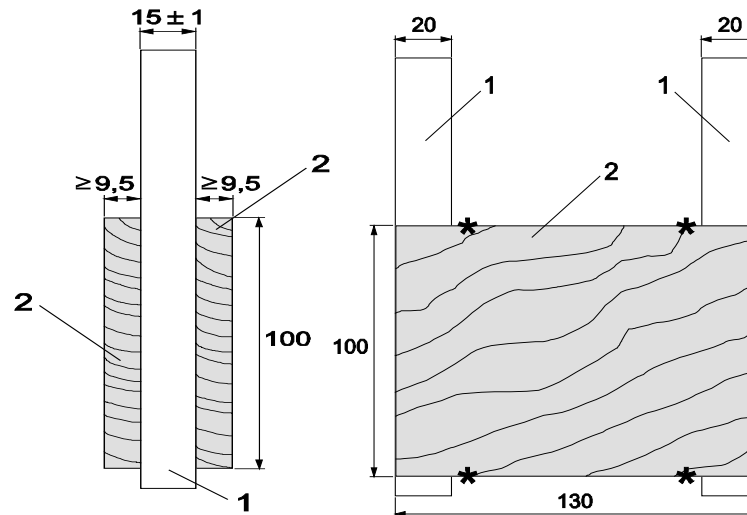

Key

- 1 Spacer
- 2 Plywood
- * Locations for determination of thickness after exposure

Figure B.1 – Specimens for determination of dimensional stability – side view

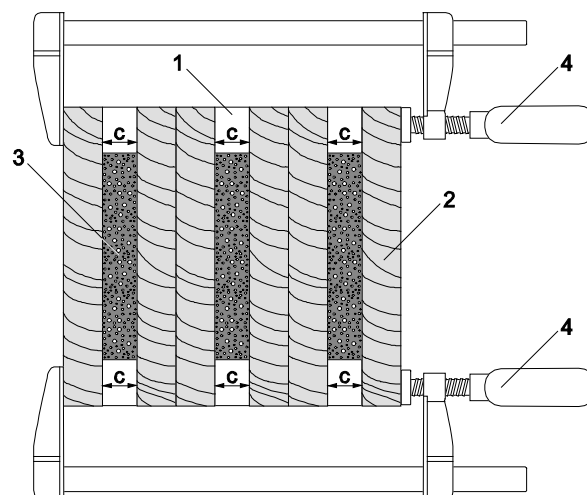

Key

- 1 Spacer
- 2 Plywood
- 3 Foam
- 4 Clamps
- c Dimension of the specimens determined after exposure

Figure B.2 – Specimens for determination of dimensional stability – top view

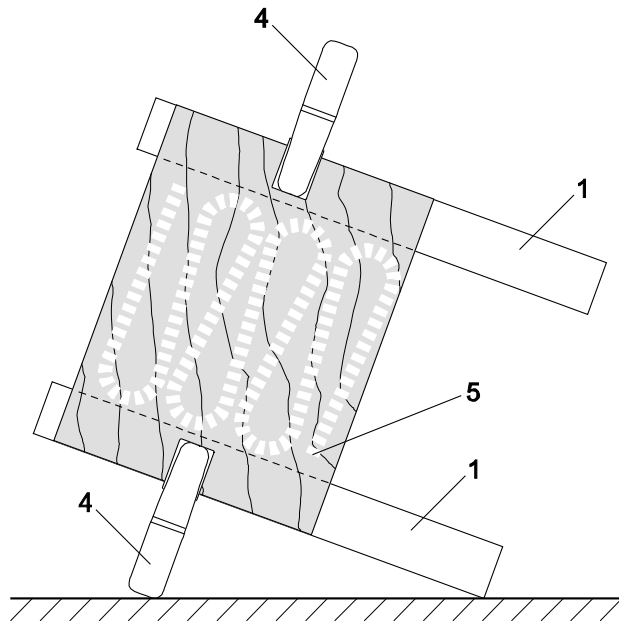

Key

- 1 Spacer
- 4 Clamps
- 5 Starting point for foaming

Figure B.3 – Set-up for foaming

B.11.2 Linear expansion on setting (gypsum based mortar)

B.11.2.1 General

The linear expansion on setting shall be determined in continuous damp air storage by means of a simple extensometer described in B.11.2.2 with the neat plaster gauged to a standard final coat consistence. The plaster shall be stabilised before test by the method described in B.11.2.5.

B.11.2.2 Extensometer

The extensometer has an open V-shaped cradle closed at one end by a fixed plate and at the other end by a movable partition, carried on the stem of an ordinary watch pattern dial micrometer gauge reading to 1/100 mm (see Fig. B.4). The cradle is of brass or bronze 100 mm long, about 60 mm wide and 25 mm deep with a rounded bottom. The take-up or returning spring shall be light and the movement free.

To prevent the plaster sticking to the sides of the cradle, grease before use and line internally with thin non-absorbent paper having a glazed surface. Renew the paper lining for each test. Fill the gauged plaster into the cradle while the movable plate is held against the end, and stoke off smooth and level with the top of the cradle.



Figure B.4 – Extensometer

B.11.2.3 Zero adjustment

Move the movable partition very slightly forward clear of the end to eliminate backlash. Bring the plaster solid against the movable partition. Make any necessary zero adjustment on the dial.

B.11.2.4 Gauging and measurement

A convenient quantity of plaster to use is about 200 g. Gauge this with water in the manner and to the standard final coat consistence described in B.11.2.6. Fill the gauged plaster immediately into the cradle of the extensometer and adjust the zero point as described in B.11.2.3. Place the extensometer in the damp closet and note the zero reading. Leave it undisturbed for 24 hours and then take the final reading. Calculate the percentage linear expansion

$$\text{Percent linear expansion} = \frac{\text{difference in dial readings in } 1/100 \text{ mm}}{100}$$

B.11.2.5 Method of stabilizing plasters

Expose the plaster for 3-4 days in a layer not more than 12 mm in thickness to an atmosphere of $(65 \pm 3) \% \text{ RH}$ at a temperature of $(20 \pm 5)^\circ\text{C}$ with vigorous air circulation over the specimen throughout this period.

If a conditioned room is not available, maintain the humidity by means of a saturated solution of ammonium nitrate contained together with the solid salt in a wide dish, and placed in a tightly-closed cabinet. Keep the air in the cabinet moving over both solution and plaster.

B.11.2.6 Standard consistence

The standard final coat consistence shall be determined by means of a dropping ball penetrometer precisely as described below.

Fill a ring mould made from a rigid material, 100 mm internal diameter, 25 mm internal depth with the paste under test. Rest the mould on a non-porous plate, fill it by using a flexible palette-knife in about ten increments in such a manner as to eliminate voids or air-bubbles. Smooth off the surface of the paste level with the top of the mould.

Drop a 25 mm diameter methylmethacrylate (MMA) ball of a mass of $(9,8 \pm 1) \text{ g}$ from rest from a height of 250 mm measured from the bottom of the ball to the surface of the paste, so that it falls approximately into the centre of the ring. Record the penetration as the distance from the lowest point of the ball to the level of the original surface of the material.

Measure the depth of penetration by a suitable method.

The paste is of the correct consistence, when the ball penetrates 15 mm to 16 mm.

When early stiffening occurs, 0,1 g of sodium citrate may be added to the gauging water for the determination of consistence.

B.12 Visual examination

The appearance of the product shall be examined for changes in colour, texture, shape and for the appearance of cracks, fissures etc. If changes in appearance are not reflected in the results of the examination of the other properties given in clause 2.4.12.1.3.2, possible consequences of the changes in appearance, on durability, shall be assessed on a case by case basis.

ANNEX C

Water Permeability – Test Method

C.1.1 Test sample

A sample representative of the fire stopping or fire sealing product shall be used to prepare a blank penetration seal following the installation instructions of the manufacturer. If a splice is required to construct longer seals a single splice shall be included in the test specimen.

C.1.2 Conditioning

The test specimen shall be conditioned in accordance with EN 13238.

C.1.3 Test apparatus

The water leakage test apparatus shall consist of a container open both ends the base of which shall form a watertight seal against the test specimen. The container shall accommodate a specimen of minimum 1 m length and the intended width and sufficient part of the supporting construction.

C.1.4 Test procedure

The water leakage test apparatus shall be sealed to the test specimen using non-hardening sealants, pressure-sensitive tape or rubber gaskets with clamping devices.

Water, with a permanent dye, shall be placed in the water leakage test chamber. The water shall cover the penetration seal to a depth corresponding to the required pressure²⁶, which shall be maintained during the test.

The temperature of the test assembly shall be maintained within a range of (23 ± 5) °C.

A white indicating medium shall be placed immediately below the test specimen.

The test shall be continued until leakage is observed or a maximum of 72 hours.

C.1.5 Evaluation of the test results

The leakage of water through the penetration seal shall be noted by the presence of water or dye on the indicating media or droplets appear on the underside of the test assembly.

C.1.6 Recorded test data

The result is given as “water tight to x mm head of water” or “water tight to x Pa”.

The test report shall include the following:

- a) A description of the assembly and materials of the linear joint seal under test, including drawings depicting geometry, exact size (length, width, and thickness), and location of the seal within the test assembly.
- b) The relative humidity of the test assembly and linear joint seal materials, if applicable.

²⁶ Requirement from a regulation or comparable specification

Addendum: Model ETA for ETA issued on the basis of ETAG 026, part 2

Cover page of the ETA

according to Document 5.1 (new ETA), Document 5.2 (modified ETA) or Document 5.3 (ETA with extended period of validity), as relevant.

Page 2 of the ETA

with headline Page 2 of ETA-xx/xxxx, issued on dd.mm.yyyy[, validity extended on dd.mm.yyyy]

I LEGAL BASES AND GENERAL CONDITIONS

- 1 This European Technical Approval is issued by ...*(name of Approval Body)* in accordance with:
 - Council Directive 89/106/EEC of 21 December 1988 on the approximation of laws, regulations and administrative provisions of Member States relating to construction products²⁷ modified by Council Directive 93/68/EEC²⁸ and Regulation (EC) N° 1882/2003 of the European Parliament and of the Council²⁹;
 - ...*(indicate respective national law transposing the CPD; only if the national law of the Member State of the issuing Approval Body so requires)*;
 - Common Procedural Rules for Requesting, Preparing and the Granting of European Technical Approvals set out in the Annex to Commission Decision 94/23/EC³⁰;
 - Guideline ...*(indicate title and number of ETA Guideline on the basis of which the ETA is granted, unless ETA is issued without an ETA Guideline in accordance with point 3.2 of the Common Procedural Rules, pursuant to Article 9(2) of the CPD)*.
- 2 The ...*(name of issuing Approval Body)* is authorized to check whether the provisions of this European Technical Approval are met. Checking may take place in the manufacturing plant(s). Nevertheless, the responsibility for the conformity of the products to the European Technical Approval and for their fitness for the intended use remains with the holder of the European Technical Approval.
- 3 This European Technical Approval is not to be transferred to manufacturers or agents of manufacturers other than those indicated on page 1, or manufacturing plants other than those /indicated on page 1/ laid down in the context/ of this European Technical Approval *(delete as appropriate)*.
- 4 This European Technical Approval may be withdrawn by ...*(name of issuing Approval Body)*, in particular pursuant to information by the Commission according to Article 5(1) of Council Directive 89/106/EEC.
- 5 Reproduction of this European Technical Approval including transmission by electronic means shall be in full. However, partial reproduction can be made with the written consent of ...*(name of issuing Approval Body)*. In this case partial reproduction has to be designated as such. Texts and drawings of advertising brochures shall not contradict or misuse the European Technical Approval.
- 6 The European Technical Approval is issued by the Approval Body in its official language(s). This (These) version(s) corresponds (correspond) fully to the version circulated in EOTA. Translations into other languages have to be designated as such.

²⁷ Official Journal of the European Communities N° L 40, 11.2.1989, p. 12

²⁸ Official Journal of the European Communities N° L 220, 30.8.1993, p. 1

²⁹ Official Journal of the European Union N° L 284, 31.10.2003, p.1

³⁰ Official Journal of the European Communities N° L 17, 20.1.1994, p. 34

Page 3 and following pages of the ETA

with headline Page ... of ETA-xx/xxxx, issued on dd.mm.yyyy[, validity extended on dd.mm.yyyy]

II SPECIFIC CONDITIONS OF THE EUROPEAN TECHNICAL APPROVAL

1 Definition of product(s) and intended use

1.1 Definition of the construction product

This European technical approval refers to ... (*cable, pipe or mixed penetration seal or seal for penetrations of ...*) with the designation "...".

(Specific text: description of the seal (e.g. design of the seal, details of the materials and the dimensions of the seal (e.g. maximum size and minimum thickness of the seal, layer thickness of a coating,...), details regarding permissible fasteners or required framings), instructions for the installation of the seal (e.g. sequence of work steps), details of permissible changes (e.g. retrofitting of services).

1.2 Intended use

(Specific text: description of type and thickness of the separating elements in which the seal is allowed to be installed, details of the services for which the seal can be used (e.g. cable types, cable trays or ladders, pipe materials, pipe diameters, pipe wall thickness, insulation materials, insulation thickness (if relevant referring to the pipe dimensions)), details of separation (between the services, between the services and the seal edge and between seals), the infill rate, the type and location of service support(s), the use category, are special pipe installations permissible?

Definition of "cable bundle" (analogue to EN 1366-3:2009, section A.1.8) shall be given.

In cases, where the penetration seal was not evaluated as if it was to be used for exposed applications (type X), the following text shall be used:

Although the penetration seal is intended for indoor applications only, the construction process may result in it being subjected to more exposed conditions for a period before the building envelope is closed. For this case provisions shall be made to protect temporarily exposed penetration seals according to the instructions of the manufacturer.

The provisions made in this European technical approval are based on an assumed working life of the ...(*product*) of ... years. The indications given on the working life cannot be interpreted as a guarantee given by the producer, but are to be regarded only as a means for choosing the right products in relation to the expected economically reasonable working life of the works.

2 Characteristics of product(s) and methods of verification

..... (*Specific text*)

The following statements may be considered for inclusion in the ETA:

General:

"Other parts or support constructions shall not penetrate the seal."

"Provisions shall be taken such that floor penetration seals cannot be stepped on or are not subjected to forces higher than the limit taken from the impact tests, e.g. by covering with a wire mesh."

"The service support construction shall be fixed to the building element on both sides of the penetration in such a manner that in the case of fire no additional load is imposed on the seal. Furthermore it is assumed that this support is maintained for the required period of fire resistance."

Cable penetration seals/ Mixed penetration seals:

"For tied cable bundles the space between the cables needs not be sealed."

"The total cross section of the cables (including cable supporting systems like cable trays etc.) shall not be more than 60% of the total seal (opening) size." *or (for mixed penetration seals):*

"The total cross section of the cables (including cable supporting systems like cable trays etc.) and pipes (the outer diameter to be considered) shall not be more than 60% of the total seal (opening) size."

Pipe penetration seals/ Mixed penetration seals:

"Pipes shall be perpendicular to the seal surface." *(to be used when only tests according to the standard configuration are available).*

"Plastic pipes for non-combustible liquids and fluids only, for pneumatic dispatch systems and for vacuum cleaning pipes."

"It is assumed that compressed air systems are switched off by other means in the case of fire."

"The function of the pipe seal in case of pneumatic dispatch systems, pressurized air systems etc. is guaranteed only when the systems are shut off in case of fire."

"The assessment does not cover the avoidance of destruction of the seal or of the abutting building element(s) by forces caused by temperature changes in case of fire. This has to be considered when designing the piping system."

Note Ad.1: For example, for non-insulated metal pipes the elongation to be considered can be calculated using the relevant temperature from the standard time temperature curve at the fire resistance period required.

"The approval does not address any risks associated with leakage of dangerous liquids or gases caused by failure of the pipe(s) in case of fire."

"The durability assessment does not take account of the possible effect of substances permeating through the pipe on the penetration seal."

"It is assumed that thermal movement in the pipe work will be accommodated in such a way that it does not impose a load on the penetration seal."

2.[...] Emission of dangerous substances or radiation

..... *(Specific text)*

Note Ad.2: In addition to the specific clauses relating to dangerous substances contained in this European Technical Approval, there may be other requirements applicable to the products falling within its scope (e.g. transposed European legislation and national laws, regulations and administrative provisions). In order to meet the provisions of the Construction Products Directive, these requirements need also to be complied with, when and where they apply.

3 Evaluation and attestation of conformity and CE marking

3.1 System of attestation of conformity

According to the decision 1999/454/EC of the European Commission³¹ the system 1 of attestation of conformity applies.

This system of attestation of conformity is defined as follows:

System 1: Certification of the conformity of the product by a approved certification body on the basis of:

(a) Tasks for the manufacturer:

- (1) factory production control;
- (2) further testing of samples taken at the factory by the manufacturer in accordance with a prescribed test plan;

(b) Tasks for the approved body:

- (3) initial type-testing of the product;
- (4) initial inspection of factory and of factory production control;
- (5) continuous surveillance, assessment and approval of factory production control.

³¹ Official Journal of the European Communities L 178 of 14/07/1999

3.2 Responsibilities

3.2.1 Tasks of the manufacturer

3.2.1.1 Factory production control

The manufacturer shall exercise permanent internal control of production. All the elements, requirements and provisions adopted by the manufacturer shall be documented in a systematic manner in the form of written policies and procedures, including records of results performed. This production control system shall ensure that the product is in conformity with this European technical approval.

The manufacturer may only use initial / raw / constituent materials (*as relevant*) stated in the technical documentation of this European technical approval.

The factory production control shall be in accordance with the "Control Plan of ...(*date*) relating to the European technical approval ETA -...(*number*) issued on ...(*date*)" which is part of the technical documentation of this European technical approval. The "Control Plan" is laid down in the context of the factory production control system operated by the manufacturer and deposited at the ...(*name of the Approval Body*).³²

The results of factory production control shall be recorded and evaluated in accordance with the provisions of the "Control Plan".

3.2.1.2 Other tasks of manufacturer

..... (*Specific text, if relevant*)

Additional information

The manufacturer shall provide a technical data sheet and an installation instruction with the following minimum information (*as far as relevant*):

Technical data sheet:

- Field of application:
 - Building elements for which the penetration seal is suitable, type and properties of the building elements like minimum thickness, density, and - in case of lightweight constructions - the construction requirements.
 - Services for which the penetration seal is suitable, type and properties of the services like material, diameter, thickness etc. in case of pipes including insulation materials; necessary/allowed supports/fixings (e.g. cable trays)
 - Limits in size, minimum thickness etc. of the penetration seal
- Construction of the penetration seal including the necessary components and additional products (e.g. backfilling material) with clear indication whether they are generic or specific.

Installation instruction:

- Steps to be followed
- Procedure in case of retrofitting.
- Stipulations on maintenance, repair and replacement

The manufacturer shall, on the basis of a contract, involve a body (bodies) which is (are) approved for the tasks referred to in section 3.1 in the field of ...(*product*) in order to allow the manufacturer to undertake the actions laid down in section 3.3. For this purpose, the "control plan" referred to in sections 3.2.1.1 and 3.2.2 shall be handed over by the manufacturer to the approved body or bodies involved.

The manufacturer shall make a declaration of conformity, stating that the construction product is in conformity with the provisions of the European technical approval ETA ...(*number*) issued on ...(*date*).

3.2.2 Tasks of approved bodies

The approved body (bodies) shall perform the

- initial type-testing of the product,
- initial inspection of factory and of factory production control,
- continuous surveillance, assessment and approval of factory production control,

in accordance with the provisions laid down in the "Control Plan of ...(*date*) relating to the European technical approval ETA -...(*number*) issued on ...(*date*)".

The approved body (bodies) shall retain the essential points of its (their) actions referred to above and state the results obtained and conclusions drawn in (a) written report (reports).

The approved certification body involved by the manufacturer shall issue an EC certificate of conformity of the product stating the conformity with the provisions of this European technical approval.

In cases where the provisions of the European technical approval and its "Control Plan" are no longer fulfilled the certification body shall withdraw the certificate of conformity and inform the ...*(name of Approval Body)* without delay.

3.3 CE marking

The CE marking shall be affixed on the ...*(product itself - indicate where on the product, if necessary; or the label attached to it; packaging; accompanying commercial document)*. The marking „CE“ shall be followed by the identification number of the approved certification body and be accompanied by the following additional information:

- the name and address of the producer (legal entity responsible for the manufacturer),
- the last two digits of the year in which the CE marking was affixed,
- the number of the EC certificate of conformity for the product,
- the number of the European technical approval,
- the number of the guideline for European technical approval
- the penetration seal name and use category/categories of the product as listed in accordance with the provisions of the ETAG.

Example(s) of CE marking and accompanying information for ...*(product)*:

 1234	<p>"CE"-marking</p> <p>Identification number of approved certification body</p>
Any company Street 1, City, Country 04 1234-CPD-0321 ETA-10/XXYZ ETAG N° 026 part 2 Penetration Seal "NAME"	<p>Name and address of the producer (legal entity responsible for the manufacturer)</p> <p>Two last digits of year of affixing the CE marking</p> <p>Number of EC certificate of conformity</p> <p>Number of European technical approval</p> <p>Number of guideline for European technical approval</p> <p>Name</p>
"see ETA-10/XXYZ for relevant characteristics"	<p>Reference to the ETA for relevant characteristics</p>

..... *(If the content of the CE marking and accompanying information is not the same for all products covered in the ETA, give further examples of CE marking and accompanying information for each of the possible cases in accordance with the provisions of the ETAG)*

4 Assumptions under which the fitness of the product(s) for the intended use was favourably assessed

4.1 Manufacturing

..... *(Specific text, as far as relevant)*

The European technical approval is issued for the product on the basis of agreed data/information, deposited with the ...*(Approval Body name)*, which identifies the product that has been assessed and judged. Changes to the product or production process, which could result in this deposited data/information being incorrect, shall be notified to the ...*(Approval Body name)* before the changes

are introduced. The ...(*Approval Body name*) will decide whether or not such changes affect the ETA and consequently the validity of the CE marking on the basis of the ETA and if so whether further assessment or alterations to the ETA, shall be necessary.

4.2 Installation

..... (*Specific text, as far as relevant*)

5 Indications to the manufacturer

5.1 Packaging, transport and storage

..... (*Specific text, as far as relevant*)

5.2 Use, maintenance, repair

..... (*Specific text, as far as relevant*)

ANNEX 1 - DESCRIPTION OF PRODUCT(S)

..... (*Specific text and/or drawings, as far as relevant*)

No commercial documents shall be part of the ETA. Only required details shall be given in the ETA. Otherwise it is not clear, which details are requirements and which are only for information.

..... (*Give further annexes as far as necessary*)