



European Organisation for Technical Approvals
Europäische Organisation für Technische Zulassungen
Organisation Européenne pour l'Agrément Technique

ETAG 001

Edition 1997

GUIDELINE FOR EUROPEAN TECHNICAL APPROVAL
OF
METAL ANCHORS
FOR USE IN CONCRETE

Part three: UNDERCUT ANCHORS

EOTA, rue du Trône 12 Troonstraat, B - 1000 Brussels

INTRODUCTORY NOTES

In this Part requirements, criteria and test information additional to Part 1 and applicable only for undercut anchors are given. The same numbering of paragraphs as in Part 1 is used. If a paragraph is not mentioned, then the text in Part 1 applies without modification.

TABLE OF CONTENTS

PART THREE: UNDERCUT ANCHORS

2 SCOPE

- 2.1 Anchors
 - 2.1.1 Types and operating principles
 - 2.1.1.1 Displacement-controlled installations
 - 2.1.1.2 Torque-controlled installations

4 REQUIREMENTS FOR WORKS

- 4.1.2.6 Types of installation

5 METHODS OF VERIFICATION

- 5.1 Methods related to 4.1 (mechanical resistance and stability)
 - 5.1.2 Tests for suitability
 - 5.1.3 Tests for admissible service conditions

6 ASSESSING AND JUDGING THE FITNESS OF ANCHORS FOR AN INTENDED USE

- 6.1 Assessing and judging related to 4.1 (mechanical resistance and stability)
 - 6.1.1.1 Criteria valid for all tests
 - 6.1.2.2.7 Minimum spacing s_{min} and minimum edge distance c_{min}
- 6.7 Identification of anchors

2 SCOPE

2.1 Anchors

2.1.1 Types and operating principles

Undercut anchors are characterised by mechanical interlock provided by undercut in the concrete.

The undercutting can be achieved by:

- Hammering or turning (or combination of both) the anchor sleeve into a drilled undercut hole.
- Driving the anchor sleeve on to the tapered bolt in a cylindrical hole either by hammering or turning (or combination of both). The concrete is mostly cut away rather than compressed.

The expansion into the undercut position shall be easily verifiable after anchor installation, e.g. by a mark on the anchor.

The following types of installations can be distinguished

2.1.1.1 Displacement-controlled installations

With anchors according to Fig. 2.1, 2.2, 2.4 and 2.5, the cylindrical holes should be drilled with a stop-drill to ensure their correct depth.

a) **Undercut drilled before anchor installation**

The different types of anchor installation are described in Figures 2.1 to 2.3:

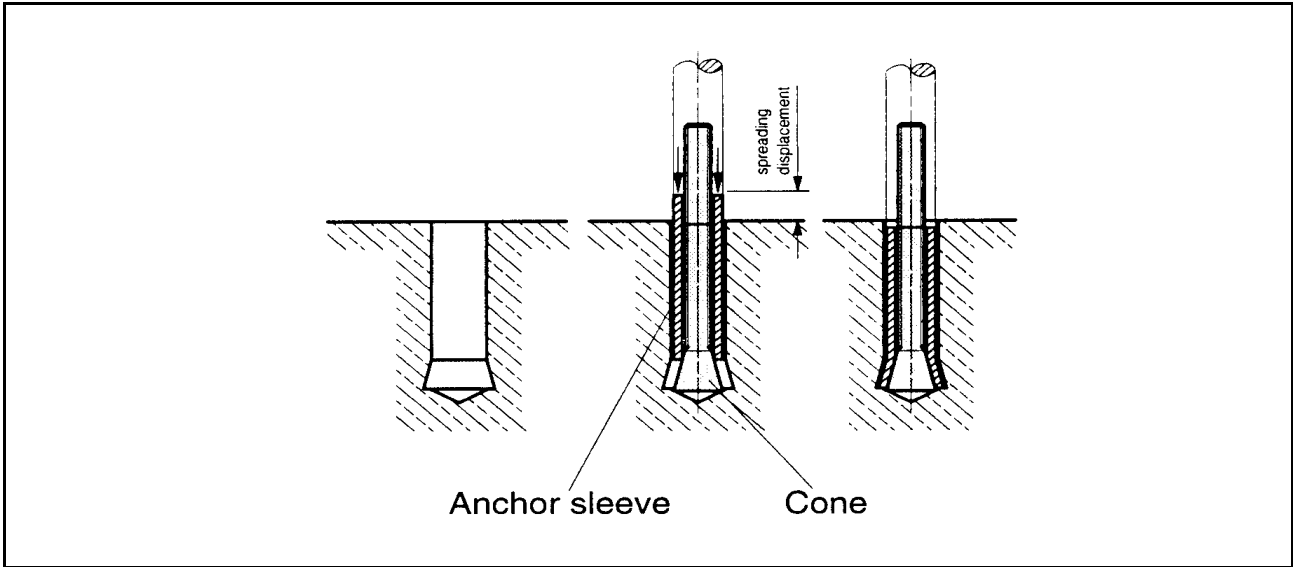

Figure 2.1 Anchor installation by hammering the anchor sleeve onto the cone

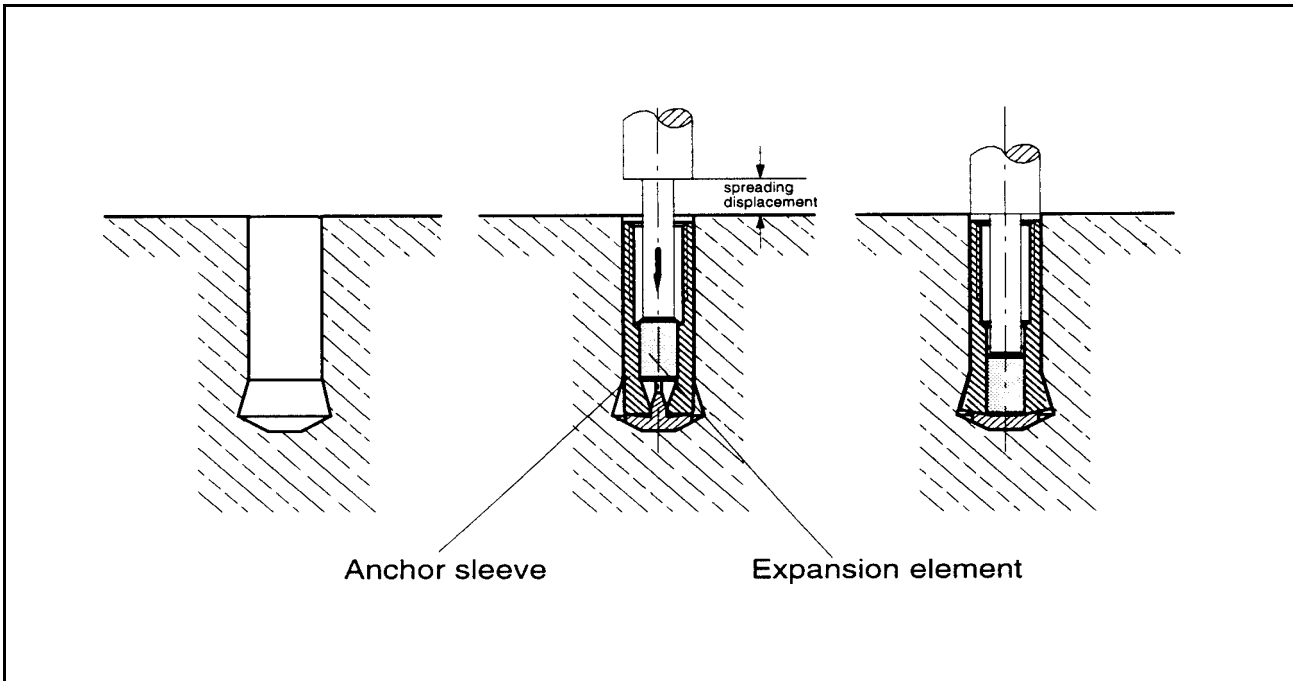

Figure 2.2 Anchor installation by hammering the expansion element (cone) into the anchor sleeve

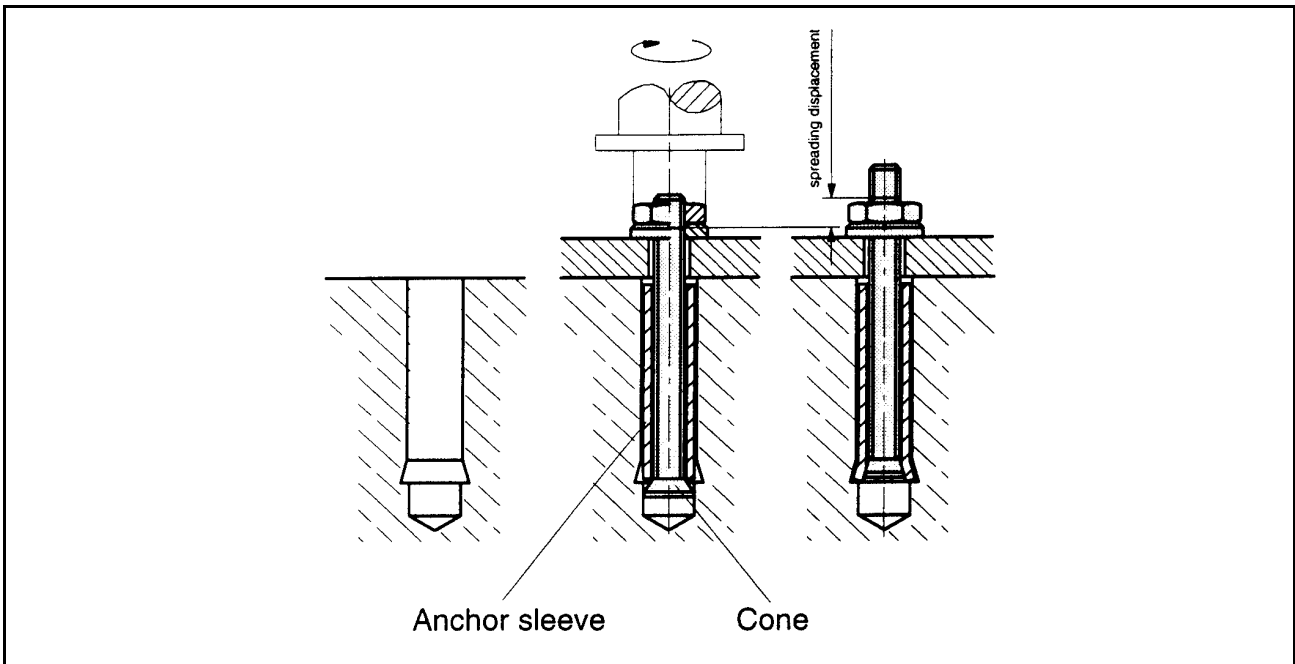

Figure 2.3 Anchor installation by pulling the cone with a defined expansion displacement into the anchor sleeve by turning the nut. This can be achieved by a special installation tool.

b) Undercut made during the setting of the anchor (self-cutting undercut anchors)

The different types of anchor installation are described in Figures 2.4 and 2.5.
A combination of Figure 2.4 and 2.5 is also possible.

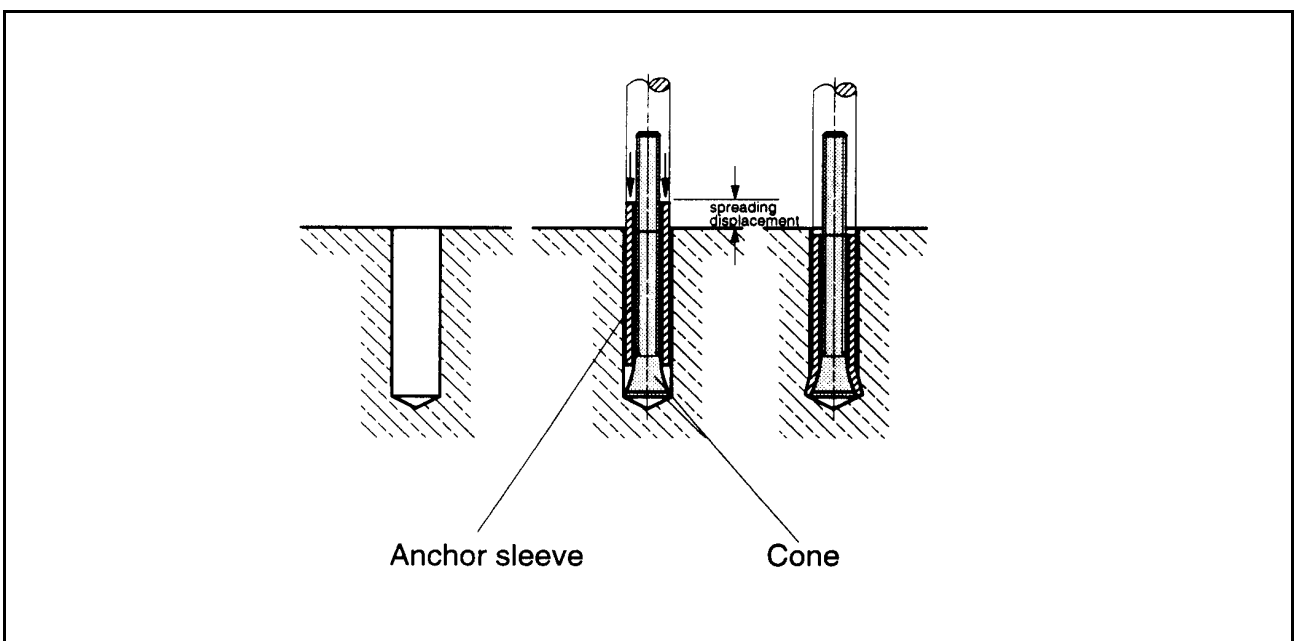

Figure 2.4 Anchor installation by hammering the sleeve over the cone; e.g. by using a drilling machine

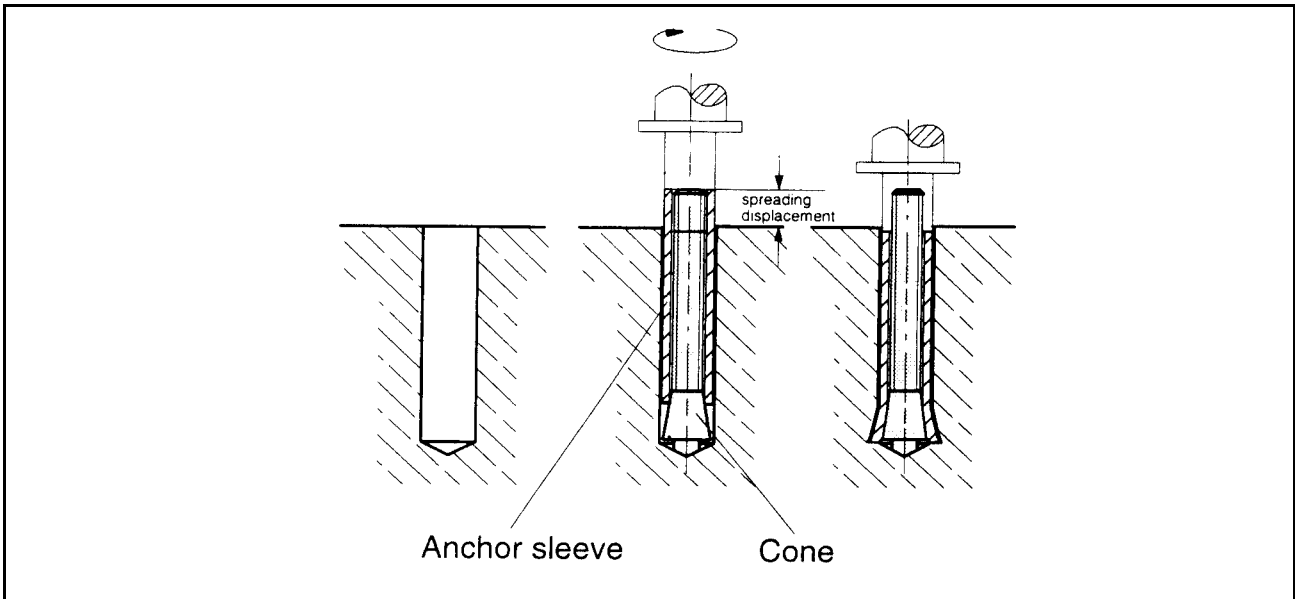

Figure 2.5 Anchor installation by rotating the anchor sleeve, e.g. by means of the drilling machine; thereby undercutting the concrete and forcing the sleeve over the cone. To facilitate the undercutting, the end of the anchor sleeve can be specially designed (e.g. with cutting pins)

2.1.1.2 Torque-controlled installations

The different types of anchor installation are described in Figures 2.6 and 2.7.

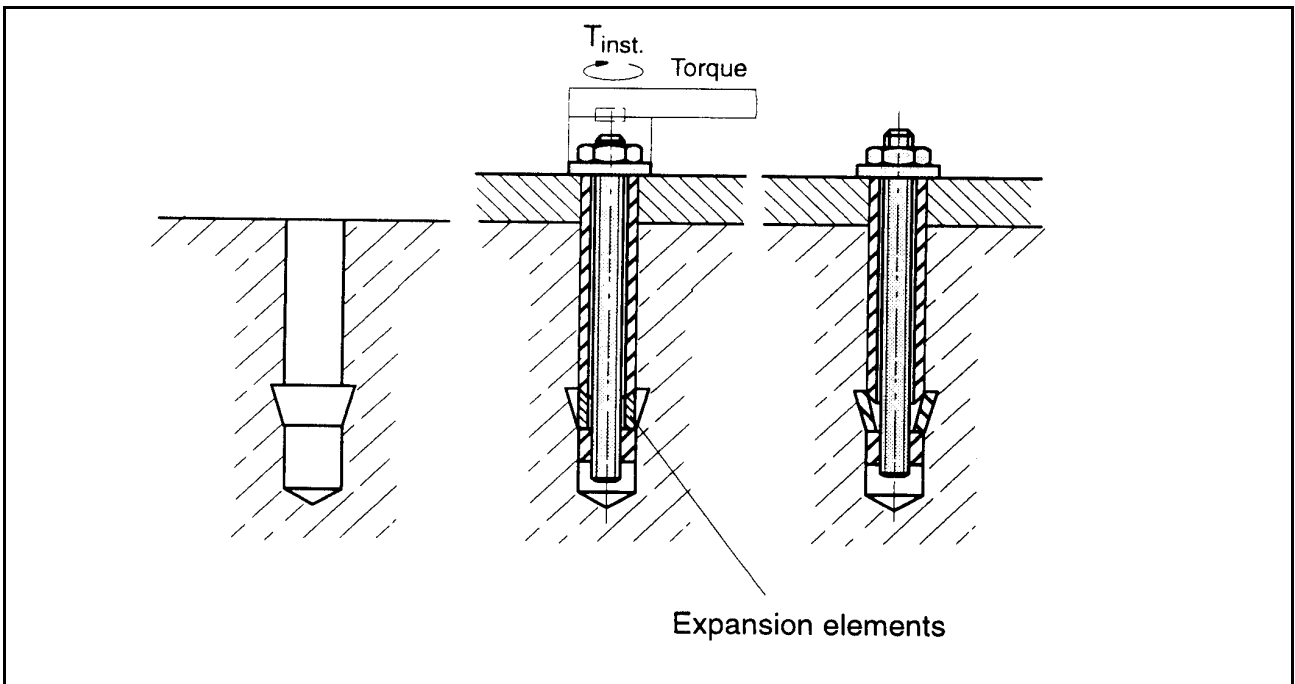

Figure 2.6 Anchor installation by forcing the expansion elements against the undercut by applying a defined torque moment

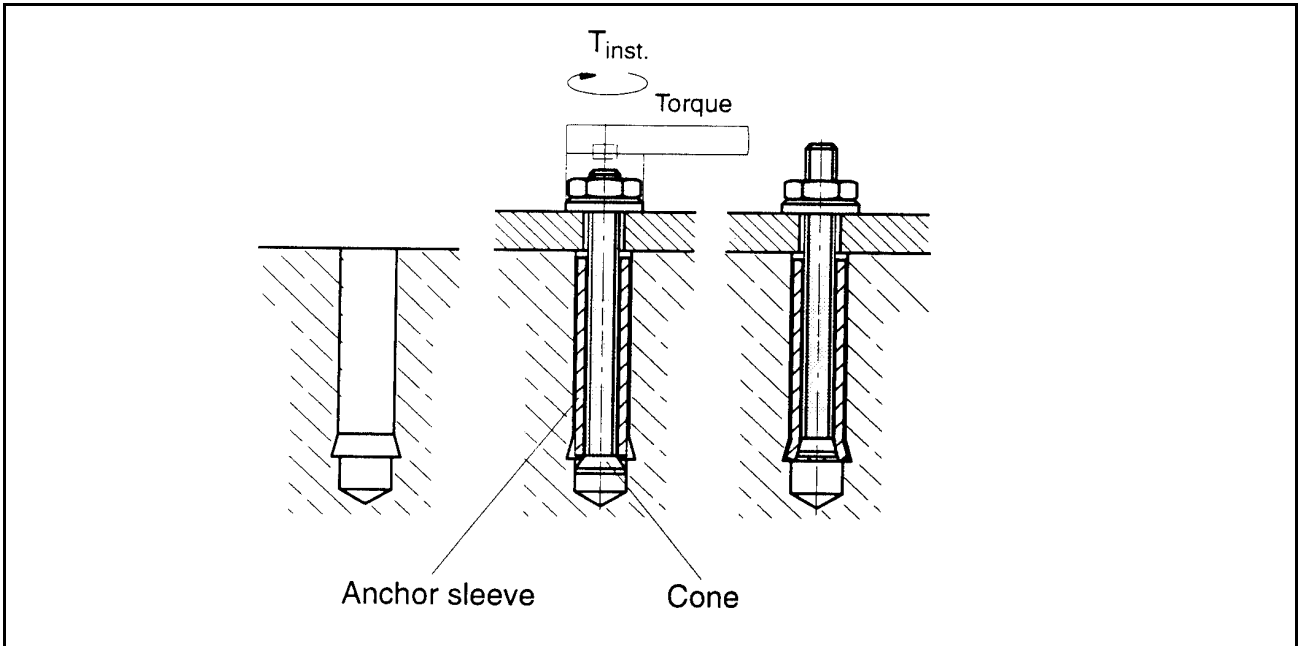

Figure 2.7 Anchor installation by pulling the cone into the anchor sleeve by applying a defined torque moment

4 REQUIREMENTS FOR WORKS

4.1.2.6 Types of installation

When installing undercut anchors by displacement control (see Figure 2.1 to 2.5), the amount of energy input for full expansion should be relatively small (e.g. up to 4 hammer blows or 15 seconds installation time with a drilling tool).

To ensure the clamping of the fixture against the concrete surface, correctly installed undercut anchors shall be positioned such, that after anchor installation including tightening the anchor with the maximum allowable torque moment, the sleeve does not bear against the fixture (pre-positioned installation) or the washer (in-place installation) respectively.

5 METHODS OF VERIFICATION

5.1 Methods related to 4.1 (mechanical resistance and stability)

In addition to the measurements required in Part 1, the following measurements should be performed and the results recorded:

Displacement-controlled installation (see Figures 2.1 to 2.5)

- Length of the stop drill (if used)
- Dimensions of the drill bit for undercutting the concrete (if used)
- Position of the sleeve in relation to the concrete surface (pre-positioned installation) or the fixture (in-place installation) respectively, after anchor expansion and after the torque moment is applied, if applicable.
- Spreading displacement (relative displacement between sleeve and cone during expansion)

Torque-controlled installation (see Figures 2.6 and 2.7)

- Dimension of the drill bit for undercutting the concrete
- Position of sleeve in relation to the concrete surface (pre-positioned installation) or the fixture (in-place installation), respectively, after the torque moment is applied.
- Number of revolutions of the nut or bolt at the applied torque moment.

5.1.2 Tests for suitability

a) General

The types of tests, test conditions and the number of required tests as well as the criteria applied to the results are given in Table 5.1. This table is valid for anchors for use in cracked and non-cracked concrete. The tests shall be performed with single anchors without edge and spacing effects under tension loading.

b) Tests

Tests according to Table 5.1, line 1

The test conditions for undercut anchors to check the installation safety in respect of anchorage intensity should be based on the anchor type and type of installation. In these tests the anchors shall be installed such that a minimum bearing area is achieved. This condition is fulfilled if the following provisions are met.

(1) Displacement-controlled installation

In general, the installation safety tests should be carried out in low strength concrete only, because in case of concrete cone failure for a constant bearing area the ratio concrete pressure in the bearing area to concrete compression strength decreases with increasing concrete strength.

Anchor installation according to Figure 2.1

- Diameter of drill bit for cylindrical hole d_0 : $d_{cut,max}$
- Length of drill bit for cylindrical hole: maximum length according to specified tolerances
- Diameter of drill bit for undercutting d_1 : $d_{cut,max}$
- Installation of anchor flush with the concrete surface or the fixture respectively.

Anchor installation according to Figure 2.2

- Diameter of drill bit for cylindrical hole d_0 : $d_{cut,max}$
- Diameter of drill bit for undercutting d_1 : $d_{cut,max}$
- Displacement of expansion element: shall be defined depending on anchor design either as a function of the required displacement, if the full anchor displacement can easily be recognized (e.g. by indentation of the anchor sleeve by the setting tool) or as a function of the required input energy for full anchor expansion or as a combination of both.

Anchor installation according to Figure 2.3

- Diameter of drill bit for cylindrical hole d_0 : $d_{cut,max}$
- Diameter of drill bit for undercutting d_1 : $d_{cut,max}$
- Expansion displacement depends on the installation tools. If the expansion can be done only with a special installation tool and the required expansion displacement can easily be recognized, then the actual expansion displacement should reflect the possible tolerances.

Installation according to Figures 2.4 and 2.5

- Diameter of drill bit for cylindrical hole d_0 : $d_{cut,max}$
- Length of drill bit for cylindrical hole: maximum length according to specified tolerances
- Installation of anchor flush with the concrete surface or the fixture respectively.

If it is required by the manufacturer to apply a defined torque moment, then the anchors shall be torqued with $T = 1.0 T_{inst}$, after about 10 minutes the torque moment shall be reduced to $T = 0.5 T_{inst}$. If no defined torque moment shall be applied, then the anchors shall not be torqued before testing ($T = 0$).

(2) Torque-controlled installation

For undercut anchors which are installed by torque control according to Figures 2.6 and 2.7 the test conditions in the installation safety tests are defined as follows:

- Diameter of drill bit for cylindrical hole d_0 : $d_{cut,max}$
- Diameter of drill bit for undercutting d_1 : $d_{cut,max}$ and $d_{cut,min}$ (anchors according to Figure 2.6 only)
- Torque moment $T = 0.5 T_{inst}$
- Concrete strength C 20/25 and C 50/60

c) Tests according to Table 5.1, lines 2 to 6

In the tests according to lines 2 to 6 the anchors should be installed according to the instructions of the manufacturer.

If for anchors installed according to Figures 2.1 to 2.5 it is required by the manufacturer to apply a defined torque moment, then the anchors shall be torqued with $T = 1.0 T_{inst}$, after about 10 minutes this torque moment shall be reduced to $T = 0.5 T_{inst}$. If for these anchors no defined torque moment shall be applied, then the anchors shall not be torqued before testing ($T = 0$).

Anchors according to Figures 2.6 and 2.7 shall be torqued with $T = 1.0 T_{inst}$; after about 10 minutes this torque moment shall be reduced to $T = 0.5 T_{inst}$.

d) Tests according to Table 5.1, line 7

In the tests according to Table 5.1, line 7, the cylindrical hole and (if required) the undercut shall be drilled with a drill bit of medium tolerances ($d_{cut,m}$). The anchor shall be installed according to the instructions of the manufacturer.

Table 5.1: Suitability tests for undercut anchors to be used in cracked and non-cracked concrete

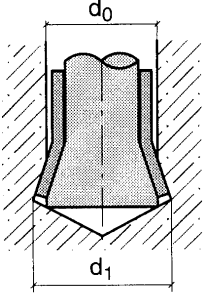
	Purpose of test	Concrete	Crack width Δw (mm)	Drill bit or diamant core bit d_{cut}		Minimum number of tests for anchor size					Criteria		Remark	Test procedure described in Annex A
						(1)					load/displacement behaviour	ultimate load req. α (3)		
				for d_0	for d_1	s	i	m	i	l				
1	Installation safety (a) anchorage intensity	C 20/25 (11)	0.3	(7)		5	5	5	5	5	Part 1, 6.1.1.1	≥ 0.8 (4)	(5), (6)	5.2.1
2	(b) contact with reinforcement	C20/25	0.3	$d_{cut,m}$	$d_{cut,m}$	5	5	-	-	-		≥ 0.7 (4)	(2), (6)	5.8
3	Functioning in low strength concrete	C20/25	0.5	$d_{cut,max}$	$d_{cut,max}$	5	5	5	5	5		≥ 0.8	(5), (6)	5.2.1
4	Functioning in high strength concrete	C 50/60	0.5	$d_{cut,min}$	$d_{cut,min}$	5	5	5	5	5		≥ 0.8	(5), (6)	5.2.1
5	Functioning in crack-movements	C 20/25	0.1 - 0.3	$d_{cut,m}$	$d_{cut,m}$	5	5	5	5	5	Part 1, 6.1.1.1 and 6.1.1.2 (a)	≥ 0.9	(5), (6)	5.5
6	Functioning under repeated loads	C 20/25	0	$d_{cut,m}$	$d_{cut,m}$	-	-	3	-	-	Part 1, 6.1.1.1 and 6.1.1.2 (b)	≥ 1.0	(8)	5.6
7	Maximum torque moment	C 50/60	0	$d_{cut,m}$	$d_{cut,m}$	5	5	5	5	5	-	(9)	(10)	5.10

Notes to Table 5.1

- (1) Anchor size
 s = smallest
 i = intermediate
 m = medium
 l = largest
- (2) Necessary only for anchors with $h_{ef} < 80$ mm to be used in concrete members with a reinforcement of spacing < 150 mm.
- (3) α see Part 1, Equation (6.2)
- (4) Valid for $\gamma_2 = 1.2$. For other values of γ_2 see Part 1, 6.1.2.2.2.
- (5) If fewer than three anchor sizes are tested together and/or the different anchor sizes are not similar in respect of geometry, then the number of tests shall be increased to 10 for all anchor sizes.
- (6) If the coefficient of variation of the failure loads is $v \geq 10$ % or the coefficient of variation of the anchor displacements at a load $F = 0.5 F_{R,u,m}$ ($F_{R,u,m}$ = average failure load in a test series) is $v \geq 30$ %, then the number of tests in this test series shall be increased to $n = 10$.
- (7) Test conditions see 5.1.2b

- (8) If anchors are not similar in respect of geometry, then other sizes shall also be tested.
- (9) See Part 1, 6.1.1.2 (d)

- (10) The number of sizes to be tested may be reduced or these tests may be omitted if it can be shown by experience that the requirement according to Part 1, 6.1.1.2 (d) will be fulfilled.
- (11) For anchors according to Figures 2.6 and 2.7 the tests shall be performed in C 20/25 and C 50/60.

5.1.3 Tests for admissible service conditions

The test conditions are given in Part 1, 5.1.3 and Annex B. They are summarized in Part 1, Table 5.4, which applies to anchors to be used in cracked and non-cracked concrete according to Option 1.

In addition to the tests in Part 1, Table 5.4, line 20 to derive the minimum edge distance and minimum spacing, tension tests according to Annex A shall be performed with double anchor group parallel to the edge ($s = s_{\min}$, $c = c_{\min}$, $h = h_{\min}$) if the average prestressing force at the maximum torque moment given by the manufacturer is smaller than the characteristic failure load for concrete failure according to Annex C.

6 ASSESSING AND JUDGING THE FITNESS OF ANCHORS FOR AN INTENDED USE

6.1 Assessing and judging related to 4.1 (mechanical resistance and stability)

6.1.1.1 Criteria valid for all tests

- a) Load/displacement behaviour

Uncontrolled slip of an anchor occurs if the expansion sleeve or expansion elements are significantly moving in the drilled hole. This can be caused by failure of the highly loaded concrete in the region of the undercut. This slip can be recognized by a reduction in load and/or a horizontal or nearly horizontal part in the load/displacement curve with a corresponding displacement of > 0.5 mm.

If uncontrolled slip is proven, refer to Part 1, 6.1.1.1a).

6.1.2.2.7 Minimum spacing s_{\min} and minimum edge distance c_{\min}

If tension tests shall be performed (see 5.1.3) then the characteristic failure load shall be equal to or larger than the value calculated according to Annex C for concrete cone failure. The largest value for c_{\min} derived from the two types of tests governs.

6.7 Identification of anchors

If the surfaces of the cone or sleeve are treated in a special way, then in addition to the tests mentioned in Part 1, the roughness of the cone surface and the inner surface of the spreading sleeve shall be measured. Furthermore, if the cone and/or the sleeve are coated, this coating shall be identified and its thickness shall be measured. The results shall be compared with the specifications.